



METEOROLOGICAL INSTRUMENTS

INSTRUCTIONS

ResponseONE-PRO™

MODEL 93000

WEATHER TRANSMITTER



OPERATING INSTRUCTIONS

Model 93000 *ResponseONE - PRO* Weather Transmitter

Contents

<u>SECTION</u>	<u>DESCRIPTION</u>	<u>PAGE</u>
1.0	INTRODUCTION	1
2.0	SPECIFICATIONS	1
3.0	BEFORE INSTALLATION	2
4.0	INSTALLATION	
4.1	Placement	2
4.2	Mounting and Alignment	2
4.3	Wiring Connections	3
5.0	OPERATION	
5.1	Serial Output Formats	3
5.2	SDI-12 Measurement Commands	4
5.2.2	SDI-12 Non-Measurement Commands	4
5.2.3	Extended Commands	5
5.3	Low Power Operation	5
6.0	SETTING SERIAL OUTPUTS AND OPERATING PARAMETERS	
6.1	Sensor Configuration with <i>ResponseONE CONFIG</i> program	6
6.2	Sensor Configuration using a General Purpose Communications Program	6
6.3	Command Overview	6
6.4	Command Details	7
7.0	EXAMPLE SETTINGS	9
8.0	EMC COMPLIANCE	9
9.0	WARRANTY	9
10.0	CE COMPLIANCE	9
<u>APPENDIX</u>		
A	WIRING CONNECTIONS	
	A1: RS-232 Serial Connection	10
	A2: RS-485 / RS-422 Serial Connection - Full Duplex	10
	A3: RS-485 / RS-422 Serial Connection - Half Duplex	11
	A4: RS-485 / RS-422 Serial Connection - Output Only	11
	A5: SDI-12 Serial Connection	12
	A6: RS-485 Serial Connection - Full Duplex (Model 26800 Translator)	12
	A7: Tipping Bucket Rain Gauge	13
B	SENSOR ORIENTATION AND DIMENSIONS	14
C	SERVICING FILTER & SENSOR MODULE	15
D	TROUBLESHOOTING	16



MODEL 93000
ResponseONE-PRO™
WEATHER TRANSMITTER

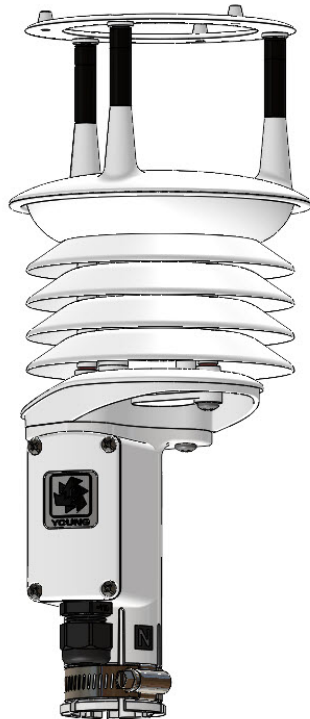

1.0 INTRODUCTION

The **Model 93000 ResponseONE-PRO™** Weather Transmitter measures four key meteorological variables with one compact instrument. It is ideal for many weather monitoring applications requiring accurate, reliable measurement.

The sensor features durable corrosion-resistant construction throughout. An ultrasonic wind sensor, atmospheric pressure sensor, temperature and humidity sensors are carefully integrated into a convenient, streamlined package. Connections are provided for optional tipping bucket rain gauge.

The *ResponseONE* installs on readily-available 1 inch (IPS) pipe. Wiring connections are made in a convenient, weather-proof junction box; special connectors and custom cables are not needed.

Measured data is output in a serial format. NMEA, SDI-12, and ASCII protocols are available to suit many applications. Continuous serial output or polled operation may be used.

RS-232 or RS-485 serial format option allows direct connection to YOUNG displays, marine NMEA systems, data loggers, or other compatible serial devices.

Operating parameters are easily reviewed and changed using the **ResponseONE CONFIG** program provided. All settings are stored internally in non-volatile memory.

The **ResponseONE-PRO™** has a unique design that allows easy removal and servicing of the internal filter and sensor module in the field. Filter cleaning is greatly simplified and the sensor module is easily replaced or recalibrated to restore the device to factory standards. See Appendix C for details.

2.0 SPECIFICATIONS

WIND SPEED

Range: 0-70 m/s (156 mph)
 Resolution: 0.01 m/s
 Accuracy: 0 - 30 m/s ±2% or 0.3 m/s
 30 - 70 m/s ±3%

WIND DIRECTION

Azimuth Range: 0-360 degrees
 Resolution: 0.1 degree
 Accuracy: ± 2 degrees

TEMPERATURE

Range: -40 - +60°C
 Resolution: 0.1°C
 Accuracy: ± 0.3°C (-20 - +50°C)
 ± 0.7°C (other)

RELATIVE HUMIDITY

Range: 0 - 100%
 Resolution: 0.1%
 Accuracy: ± 2% (5 - 95%)

ATMOSPHERIC PRESSURE

Range: 500 - 1100 hPa
 Resolution: 0.1 hPa
 Accuracy: ± 0.3 hPa (0 - 60°C)
 ± 1 hPa (-40 - 0°C)

TIPPING BUCKET RAIN GAUGE

Connection for external tipping bucket rain gauge is provided (normally open magnetic reed switch)

SERIAL OUTPUT (Selectable)

Interface Type: RS-232 or RS-485/422, SDI-12
 Formats: ASCII Text - polled or continuous
 NMEA - continuous
 SDI-12 - polled
 Baud Rates: 1200, 4800, 9600, 19200 and 38400

GENERAL

Output rate: 1 Hz typical
 Power Supply: 10 - 30 VDC,
 7 mA typical, 80 mA max
 Protection Class: IP65
 EMC Compliance: FCC Class A digital device
 IEC standard 61326-1
 Dimensions: 30 cm high x 13 cm wide
 Weight: 0.7 kg (1.5 lb)
 Shipping Weight: 1.6 kg (3.5 lb)
 Operating Temperature: -40 - +60°C

3.0 BEFORE INSTALLATION

3.0 UNPACKING THE *ResponseONE*

The *ResponseONE* comes in a custom shipping carton. Carefully inspect the instrument when first unpacking and report any visible damage to your YOUNG supplier. Be sure to retain the bird spikes and orientation ring for use.

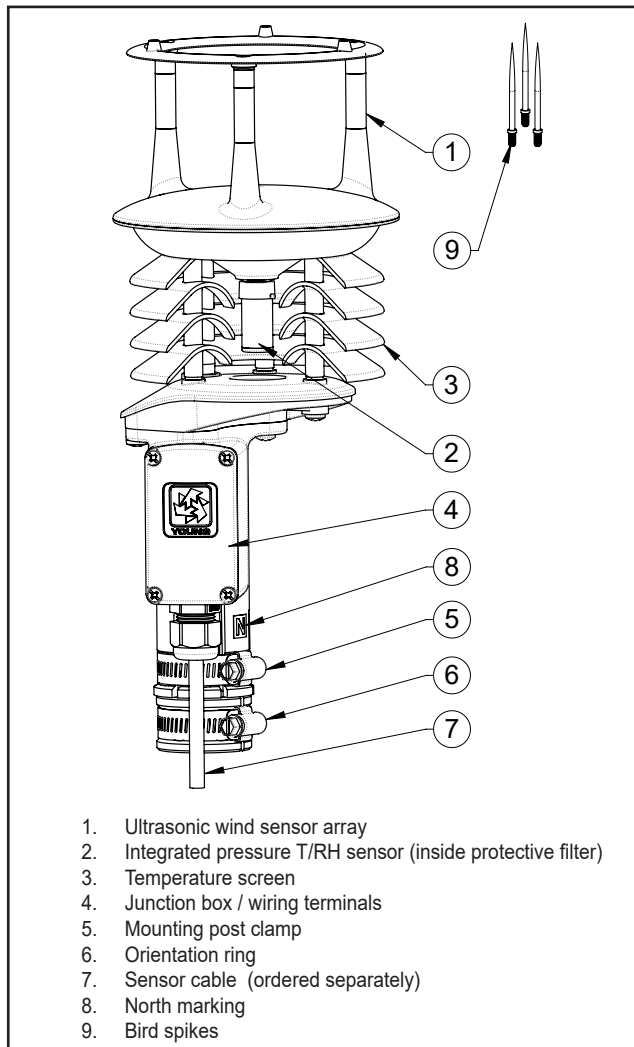

1. Ultrasonic wind sensor array
2. Integrated pressure T/RH sensor (inside protective filter)
3. Temperature screen
4. Junction box / wiring terminals
5. Mounting post clamp
6. Orientation ring
7. Sensor cable (ordered separately)
8. North marking
9. Bird spikes

Figure 3.0 *ResponseONE* - PRO Features

The *ResponseONE* arrives fully calibrated and ready to use. As supplied, the sensor is configured as follows:

FACTORY DEFAULT CONFIGURATION

Protocol:	RS-232 ASCII / RS485 (output only)
Baud Rate:	9600
Wind Format:	Polar
Wind Units:	m/s, Degrees azimuth
Temperature:	Celsius
Relative Humidity:	Percent RH
Pressure:	hPa

Default connections are shown in APPENDIX A, FIGURE A1. Other options are also described in APPENDIX A. These are selected using the ***ResponseONE* CONFIG** program which is available at www.youngusa.com. **Note: Always connect and bench test a complex system before installation in the field.**

4.0 INSTALLATION

4.1 PLACEMENT

Proper instrument placement is important. Eddies from buildings, trees, or other structures can influence measurements. Locate the sensor well away from obstructions. As a general rule, air flow around a structure is disturbed to 10 times the height of the structure downwind and 1-1/2 times the height of the structure above the roof.

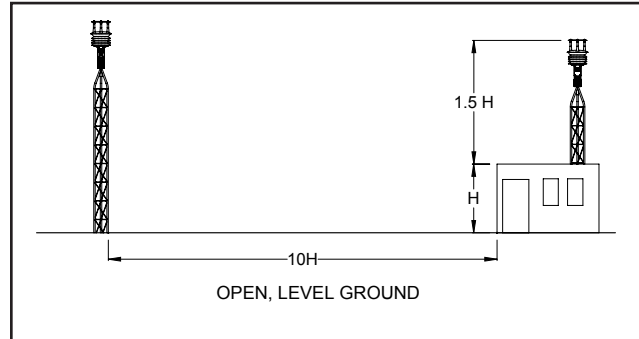

Fig 4.1 Wind Siting Considerations

4.2 MOUNTING AND ALIGNMENT

The *ResponseONE* mounts on standard 1-inch (IPS) pipe. This is commonly available steel pipe with an outside diameter of 1.315 inches (33 mm). The mounting pipe should be installed securely in a vertical orientation.

Most applications require aligning the wind sensor array to geographic north (0 degrees).

- 1 Place orientation ring over pipe with guide pin up.
- 2 Place sensor mounting post over pipe.
- 3 Obtain accurate geographic data for the installation site, this can be a topographic map, graphical GPS map or detailed road map. Using the "N" marking, align the sensor with a remote feature that represents the proper orientation (Fig 4.2.1). After alignment, tighten the mounting post band clamp to secure the position. **DO NOT OVER-TIGHTEN.**
- 4 Slide the orientation ring up so its guide pin is fully engaged in the sensor mounting post notch (Fig 4.2.2). Tighten the orientation ring band clamp to secure its position. **DO NOT OVER-TIGHTEN.**

If the *ResponseONE* is later removed, the orientation ring will preserve the sensor alignment.

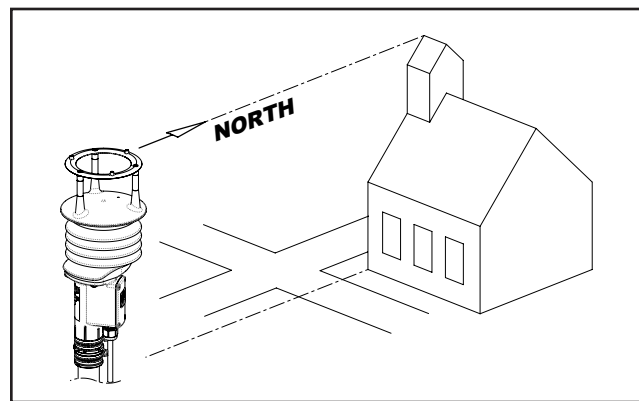

Fig 4.2.1 Sighting of Wind Sensor using Geographic Feature

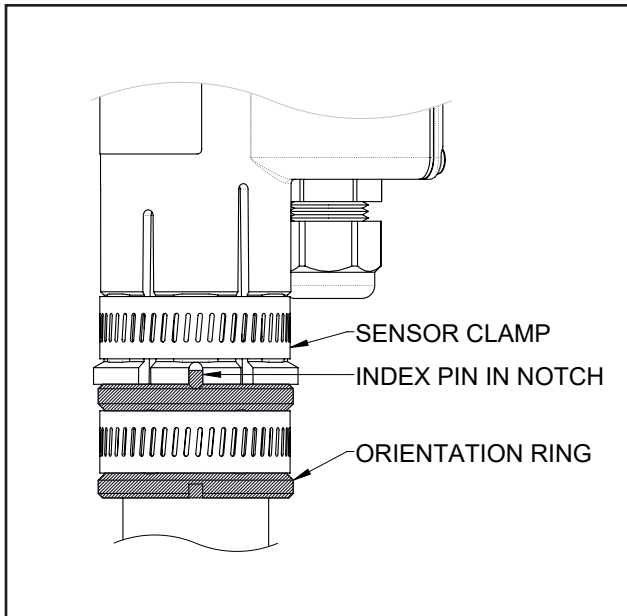

Fig 4.2.2 Proper Engagement of Orientation Ring with Sensor

4.3 WIRING CONNECTIONS

The *ResponseONE* is supplied with RS-232, RS-485 and SDI-12 signal capability. Please select the signal type desired and refer to the appropriate WIRING CONNECTIONS diagram in APPENDIX A for connecting the *ResponseONE* to your serial device. Please note, the *ResponseONE* is not equipped with analog outputs.

4.4 TIPPING BUCKET RAIN GAUGE

The *ResponseONE* has provision for connecting an optional tipping bucket rain gauge. When properly connected and configured, the total number of tips is included on the serial output message in either ASCII or SDI-12 output format. See Appendix A for details.

5.0 OPERATION

5.1 SERIAL OUTPUT FORMATS

The *ResponseONE* comes standard with the following serial output formats:

Format/Protocol	Wiring Format
ASCII Polled and Continuous	RS-232, RS-485
NMEA 0183 v3.0 Automatic	RS-232, RS-485
SDI-12 Polled	SDI-12

Detailed information about each protocol is in the following section.

If you wish to change settings from the factory default values shown in Section 3, this is easily done using the ***ResponseONE CONFIG*** program described in Section 6.0.

5.1.1 ASCII

ASCII output format provides continuous measurement data in text format at any of the available baud rates.

The wind measurement in ASCII output appears either in POLAR (default) or CARTESIAN UV format. With POLAR format, the wind speed threshold and wind speed units are user-selectable. With CARTESIAN the wind threshold is ignored and wind speed units are always meters per second (m/s).

ASCII POLAR FORMAT

```
a www.ww ddd.d ttt.t hhh.h bbbb.b ppppp ss*cc<CR>
```

where:

a = Sensor address
 www.ww = Wind speed
 ddd.d = Wind direction
 ttt.t = Temperature
 hhh.h = Relative Humidity
 bbbb.b = Barometric Pressure
 ppppp = Tipping Bucket (Optional)
 ss = Status code
 * = Asterisk (ASCII 42)
 cc = Checksum
 <CR> = Carriage return (ASCII 13)

ASCII CARTESIAN (UV) FORMAT

```
a uu.uu vv.vv ttt.t hhh.h bbbb.b ppppp ss*cc<CR>
```

where:

a = Sensor address
 ±uu.uu = U-axis wind speed (m/s)
 ±vv.vv = V-axis wind speed (m/s)
 ttt.t = Temperature
 hhh.h = Relative Humidity
 bbbb.b = Barometric Pressure
 ppppp = Tipping Bucket (Optional)
 ss = Status code
 * = Asterisk (ASCII 42)
 cc = Checksum
 <CR> = Carriage return (ASCII 13)

CHECKSUM is a two-character hexadecimal value (in printable ASCII format) generated by taking the exclusive-or of all characters up to the asterisk. STATUS CODE shows a non-zero value when the sensor cannot acquire sufficient samples or a measurement error has occurred. See APPENDIX C for more information on status codes.

5.1.2 ASCII POLLED

ASCII POLLED is like ASCII format described above except just one serial output string is sent for each polling command received. The polling command is *Ma!* where 'a' is the sensor address (valid characters: 0-9, A-Z, a-z). The default address is '0' (ASCII 48).

5.1.3 NMEA

NMEA format provides continuous measurements in standard NMEA marine sentences at 4800 baud. The *ResponseONE* must be connected to a NMEA-capable device. The NMEA data is contained in two successive data sentences. The first sentence, "MWV", contains wind data, while the second sentence, "XDR", contains temperature, relative humidity and barometric pressure data. Specific details of the NMEA data string are below:

NMEA FORMAT - part 1

```
$WIMWV,ddd,R,www.w,u,A*cc<CR><LF>
```

where:

WI = Device type (weather instrument)
 MWV = Wind direction and speed
 ddd = Wind direction (degrees)
 www.w = Wind speed
 u = Wind speed units
 S = mph
 N = knots
 K = kmph
 M = m/s
 A = Data status code: A=valid, V=invalid
 * = Asterisk (ASCII 42)
 cc = Checksum
 <CR><LF> = Carriage return, Line feed (ASCII 13,10)

Continued on next page...

NMEA FORMAT - part 2

\$WIXDR,C,ttt.t,cu,TEMP,H,hhh.h,P,RH,P,b.bbbb,pu,
BARO*cc<CR><LF>

where:

WI	= Device type (weather instrument)
XDR	= Type of measurement (transducer)
ttt.t	= Temperature
cu	= Temperature units C = Celsius F = Fahrenheit
hhh.h	= Relative humidity
b.bbbb	= Barometric Pressure
pu	= Barometric Pressure units B = Bar InHg = Inches of Mercury
*	= Asterisk (ASCII 42)
cc	= Checksum
<CR><LF>	= Carriage return,Line feed (ASCII 13,10)

CHECKSUM is the two-character printable hexadecimal value generated by taking the exclusive-or of all characters between '\$' and '*'. .

5.2 SDI-12

SDI-12 stands for serial data interface at 1200 baud. It is often used to interface battery powered data recorders with microprocessor based devices designed for environmental data acquisition. SDI-12 is used typically when low power is a concern. The SDI-12 device normally remains in a low power, standby state until it is polled at which time a measurement is sent. SDI-12 can effectively address multiple sensors on the same cable.

5.2.1 SDI-12 MEASUREMENT COMMANDS

Model 93000 uses the SDI-12 (v1.3) serial communication protocol to initiate measurements and set sensor operation parameters. The default sensor address is 0 (zero), and can be changed to any valid single-character value if needed. Additional details about the SDI-12 protocol may be found at www.sdi-12.org.

After initial power-up with 12 VDC, the sensor is in a low-power standby state with a quiescent current of 4.2 mA. A valid and properly addressed SDI-12 command wakes the sensor to initiate a measurement, set or check operating parameters. After command processing has finished, the sensor returns to the low-power standby state.

SDI-12 'M' or 'C' commands initiate a measurement. The sensor response message indicates the maximum time needed before the measurement is ready, and data values will be available. The maximum time ranges from 1 to 5 seconds depending on the Sample Count.

If an 'M' command initiates a measurement, the sensor sends a Service Request when the measurement is ready to be retrieved. When the polling device receives the Service Request it then sends a 'D' command to request measurement results from the sensor. With 'C' commands, no Service Request is sent, and the polling device must wait the full delay time before sending the 'D' command to request the measurement.

SDI-12 Measurement commands and responses are listed below.

COMMAND	RESPONSE	DESCRIPTION
aM!	at t t t s <CR><LF>	Take a measurement
aMC!	at t t t s <CR><LF>	Take a measurement with CRC checksum
aC!	at t t s s <CR><LF>	Take a concurrent measurement
aCC!	at t t s s <CR><LF>	Take a concurrent measurement with CRC checksum
aD0!	a+www.ww+ddd.d+sc<CRC><CR><LF>	(Polar)
	a±uu.uu±vv.vv+sc<CRC><CR><LF>	(Cartesian)
aD1!	a+ttt.t+hhh.h+bbbb.b+sc<CRC><CR><LF>	
	a+ttt.t+hhh.h+bbbb.b+rrrrr+sc<CRC><CR><LF>	

where:

a	= Sensor address
ttt	= Delay time (seconds)
s/ss	= Number of samples to collect
ddd.d	= Wind direction (degrees)
www.ww	= Wind speed (selected units)
±uu.uu	= U-axis wind speed (m/s)
±vv.vv	= V-axis wind speed (m/s)
+sc	=Status Code (see APPENDIX C)
ttt.t	=Temperature (selected units)
hhh.h	= Relative Humidity
bbbb.b	= Barometric Pressure (selected units)
rrrrr	= Tipping Bucket counter (Optional)
<CRC>	= CRC checksum (only where requested)
<CR><LF>	= Carriage return, line feed (ASCII 13, 10)

Wind data format depends on the sensor Output Format parameter setting (Polar or Cartesian). Rain gauge tip count is disabled by default. See extended commands to enable it.

5.2.2 SDI-12 NON-MEASUREMENT COMMANDS

The SDI-12 protocol includes standard commands for identifying the sensor and changing its address.

COMMAND	RESPONSE	DESCRIPTION
?!	a<CR><LF>	Address Query
a!	a<CR><LF>	Acknowledge Active
aI!	a13 YOUNG C092000 vvvnnnnnn<CR><LF>	Send Identification vvv = Firmware Version nnnnnn = Serial Number
aAb!	b<CR><LF>	Change Address a = Sensor address b = New sensor address
aV!	a0000<CR><LF>	Start Verification

5.2.3 EXTENDED COMMANDS

The SDI-12 command set may be customized with Extended Commands to accommodate manufacturer settings and other functions. Extended Commands are listed below. Where two responses are shown, one is for a valid command, the other is for an invalid (ERR) command.

COMMAND	RESPONSE	DESCRIPTION
aXB!	aXB, OK<CR><LF>	Save parameter settings to flash.
aXFn!	aXF, F=n<CR><LF>	n = Output Format code. 0 or 1 (Polar or Cartesian)
	aXF,ERR F=0/1<CR><LF>	
aXPn!		Parameter report, 4 reports needed for all parameters
	aXP1, F=f, UW=uw, UT=ut, UP=up, T=t, S=s, W=w<CR><LF>	
	a = Sensor address	
	f = Wind Format	
	uw = Polar wind speed units	
	1=mph	
	2=knots	
	3=km/h	
	4=m/s	
	ut= Temp units	
	up=Pressure units	
	t = Threshold, polar only (0-150 cm/s)	
	s = Sample count, internal (1-800)	
	w = Wait (seconds)	
	aXP2, OD=od, OT=ot, OH=oh, OP=op<CR><LF>	
	od=WD Offset	
	ot=Temp Offset	
	oh=RH Offset	
	op=Pressure Offset	
	aXP3, M=m, RE=re<CR><LF>	
	m=WS multiplier	
	re=Rain Enable	
	aXP4, PWR=VV.V VDC<CR><LF>	
	aXPn,ERR n=1/2/3/4 ONLY<CR><LF>	
aXSnnn!	nnn = Sample Count (001-800 samples)	
	aXS, S=nnn<CR><LF>	
	aXS,ERR S=001-800 ONLY<CR><LF>	
aXMnnnnn!	nnnnn=WS multiplier x 10000 (00000 - 30000)	
	aXM, M=nnnnn<CR><LF>	
	aXM,ERR M=00000-30000 ONLY<CR><LF>	
aXTnnn!	nnn = Wind Speed Threshold (000 - 150 cm/s)	
	aXT, T=nnn<CR><LF>	
	aXT,ERR T=000-150 ONLY<CR><LF>	
aXUWn!	n = Wind Speed Units (1=mph, 2=knots, 3=kmph, 4=m/s)	
	aXUW, UW=n<CR><LF>	
	aXUW,ERR UW=1/2/3/4 ONLY<CR><LF>	
aXUTn!	n = Temperature Units (0=C, 1=F)	
	aXUT, UT=n<CR><LF>	
	aXUT,ERR UT=0/1 ONLY<CR><LF>	

aXUPn!	n = Pressure Units (0=hPa/mBar, 1=inHg)
	aXUP, UP=n<CR><LF>
	aXUP,ERR UP=0/1 ONLY<CR><LF>
aXOT±nnn!	±nnn = Temperature Offset x 10 (-100 to 100)
	aXOT, OT=±nnn<CR><LF>
	aXOT,ERR OT=-100 - +100 ONLY<CR><LF>
aXOH±nnn!	±nnn = Humidity Offset x 10 (-100 to 100)
	aXOH, OH=±nnn<CR><LF>
	aXOH,ERR OH=-100 - +100 ONLY<CR><LF>
aXOP±nnnn!	±nnnn = Pressure Offset x10 (-5000 to 5000)
	aXOP, OP=±nnnn<CR><LF>
	aXOP,ERR OP=-5000 - +5000 ONLY<CR><LF>
aXOD±nnnn!	±nnnn = Wind Direction Offset x 10 (-3600 to 3600)
	aXOD, OP=±nnnn<CR><LF>
	aXOD,ERR OD=-3600 - +3600 ONLY<CR><LF>
aXREn!	n = Tipping Bucket Enable. 0 or 1 (Disable or Enable)
	aXRE, RE=n<CR><LF>
	aXRE,ERR RE=0/1 ONLY<CR><LF>
aXRR!	Reset Tip Count to 0
	aXRR, OK<CR><LF>

IMPORTANT! PARAMETER CHANGES MUST BE STORED IN FLASH MEMORY USING THE aXB! COMMAND OR THEY WILL REVERT TO PREVIOUSLY STORED VALUES AT POWER UP.
The aXB! command may be sent after all changes have been made, or not sent at all if the changes are temporary.

SAMPLE COUNT (aXSnnn!)

This command sets the number of internal samples used to calculate the median measurement result. More internal samples consume more power while providing greater immunity to conditions like turbulent high-speed wind. Fewer samples consume less power while providing less immunity to disruptive conditions. Default setting is 100.

THRESHOLD (aXTnnn!)

Threshold sets the minimum wind speed needed before a new polar wind direction is calculated. The default value is 25 cm/s (0.25 m/s). A greater-than-zero threshold can help provide more meaningful scalar wind direction averages. The threshold for Cartesian (UV) output format is automatically zero regardless of this setting.

5.3 LOW POWER OPERATION

Average current consumption with default settings is about 7.5 mA. This configuration uses minimal power and enables all features even though they may not be used. This is suitable for many low power applications.

To reduce current consumption further, additional strategies include disabling unused outputs, using polled serial operation, increasing the output interval, and limiting the sample count to the minimum optimal number. Faster baud rates also reduce power by limiting transmit duration.

6.0 SETTING OUTPUTS AND OPERATING PARAMETERS

6.1 SENSOR CONFIGURATION WITH *ResponseONE* CONFIG PROGRAM (RECOMMENDED)

The YOUNG *ResponseONE* CONFIG program is available from the factory web site: www.youngusa.com. It provides an easy method for checking and configuring sensor operation. Install the program on a Windows 7 or higher PC and follow instructions that appear on the program screen to retrieve current sensor settings or send new settings.

6.1.1 Opening the Program

After installing the program on your PC, click the desktop icon to open the program. The following screen should appear:

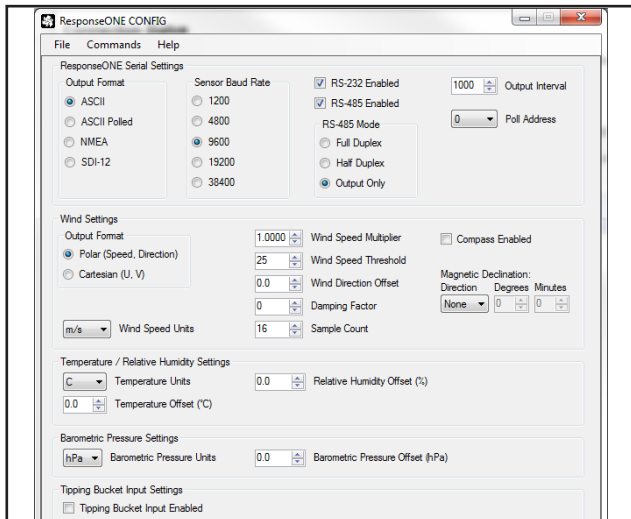

Fig 6.1 *ResponseONE* CONFIG program opening screen

If you are using the *ResponseONE* for the first time, the default settings will appear. For reference these are:

FACTORY DEFAULT CONFIGURATION

Protocol:	RS-232 ASCII / RS-485 (output only)
Baud Rate:	9600
Wind Format:	Polar
Wind Units:	m/s, Degrees azimuth
Temperature:	Celsius
Relative Humidity:	Percent RH
Pressure:	hPa

If these settings are correct for your application, then you may proceed with operation of the device. If you wish to change any settings, available options can be selected from menu items visible. After changes are made, the *ResponseONE* CONFIG program automatically saves the new settings in flash memory

6.2 SENSOR CONFIGURATION USING A GENERAL PURPOSE COMMUNICATIONS PROGRAM

A general purpose text-based serial communications program like **HyperTerminal** may be used to manually configure the sensor by sending simple text commands. The following guidelines apply:

The YOUNG sensor and communication program must operate at the same baud rate and be properly connected. Sensor RS-232 mode must be enabled. See the RS-232 wiring diagram, FIGURE A1, in APPENDIX A.

Factory default sensor baud rate is 9600, Configure the serial communications program for NO handshaking and 1 start, 8 data, 1 stop bit, no parity, no flow control.

The sensor must be in COMMAND MODE in order to set parameters.

Enter COMMAND MODE by sending three ESC characters (ASCII 27) in quick succession while the sensor is running. When the sensor is in COMMAND MODE, it sends a '>' prompt character indicating that it is ready to accept commands.

If the prompt does not appear after sending three indicating characters, re-check wiring and communication program setup. If the sensor baud rate is unknown, try sending the ESC characters at each of the five available baud rates (1200, 4800, 9600, 19200 and 38400). It is also possible that sensor parameters have been purposely configured to disable RS-232 mode. If this is the case, the following method must be used.

In order to provide access under all conditions, the sensor always begins operation at power up with serial communications set to 38400 baud and RS-232 connections enabled. Immediately after power up, there is a short time window in which to send the ESC characters and enter COMMAND MODE.

To use this feature, set your serial communication program baud rate to 38400. Remove power then wait 5 seconds. Re-apply power to the sensor. The sensor will transmit four asterisks immediately after power up. After the asterisks appear, send three ESC characters. The COMMAND MODE '>' prompt should appear. To do this using *ResponseONE* CONFIG, connect the *ResponseONE* to your computer, open the program (make sure the correct serial port is selected), then go to the 'COMMANDS' menu and select 'ACQUIRE *ResponseONE*'.

A window will come up telling you that the serial port will be set to 38400 baud. Click 'OK' to continue. Then simply apply power to the *ResponseONE* and the program will connect automatically.

6.3 COMMAND OVERVIEW

After the '>' prompt appears, send '???' to display a list of available commands. Send 'RPTV' to report current settings. (Note that some values in the report are for factory settings and cannot be changed by the user.)

Commands are case sensitive and the exact format must be used. For example, the SET01nn command requires two digits for the serial format code. If you send SET014 instead of SET0104 the sensor will reject the command and indicate an error. End all commands with a carriage return (ASCII 13). In HyperTerminal, do this by pressing the ENTER key.

After receiving the carriage return, the sensor will evaluate the command. Valid commands will be executed. Current settings can be evaluated at any time by sending RPTV to get a new report.

IMPORTANT NOTE:

The YOUNG *ResponseONE* CONFIG program automatically saves all settings to flash memory when they are sent to the sensor. Settings that are changed manually must be saved to flash with the SET77 command.

COMMAND

DESCRIPTION

SET01nn Set output mode
 SET02n Set output format
 SET03nn Set baud rate
 SET04n Set wind speed units
 SET05a Set sensor address
 SET06nnn Set wind speed threshold
 SET07nnnnn Set wind speed multiplier
 SET08±nnnn Set direction offset
 SET09dd Set damping factor
 SET10nnnn Set output interval
 SET12nnn Set sample count
 SET13n Set wind output format
 SET14n Set temperature units
 SET15n Set pressure units
 SET16±nnnn Set temperature offset
 SET17±nnnn Set relative humidity offset
 SET18±nnnn Set pressure offset
 SET27 Set tipping bucket count to 0
 SET28n Enable tipping bucket
 SET77 Save settings
 XX Operate mode
 RPTV Report current settings
 ?? Display command list
 HELP Display command list

polling with the "aM!" command (SDI-12) and 'Ma!' command (ASCII Polled) where 'a' is the address. Default value is 0.
 0-9, A-Z, or a-z
 Where a=
 Usage example:
 >SET052 Sets polling address to number 2.
 SET06nnn Set the wind speed threshold. Minimizes erratic wind direction indications at very low wind speeds. In polar mode, this allows the sensor output to mimic a mechanical wind vane that retains its orientation when there is no wind. Default value is 25.
 000-150 cm/s
 Where nnn=
 Usage example:
 >SET06025 Sets wind speed threshold to 25 cm/s.
 SET07nnnnn Set wind speed multiplier. Value is x10000. All wind speed measurements are multiplied by this parameter. Default value is 10000 for a multiplier of 1.0000.
 00000-30000
 Where nnnnn=
 Usage example:
 >SET0709909 Sets multiplier to 0.9909
 >SET0710023 Sets multiplier to 1.0023
 SET08±nnnn Set wind direction offset. Value is degrees x10 and may be positive or negative. Wind direction is always re-scaled to a 0-360 range after offset is applied. Default value is 00000.
 -3600 to +3600
 Where ±nnnn=
 Usage example:
 >SET08-0012 Offsets wind direction reading by -1.2 degrees
 >SET08+0005 Offsets wind direction reading by +0.5 degrees
 SET09dd Set damping factor. Default value is 00. This means no damping is applied. High damping values at long output intervals can slow the rate at which indicated wind values change. Wind measurement outputs are damped using the following formula:

$$S_{damped} = [(dd-1) * S_{damped} + S_{sample}] / dd$$

 Damping factor (00-99)

$$S_{damped} = \text{New or last damped wind speed}$$

$$S_{sample} = \text{New wind speed}$$

 Usage example:
 >SET0905 Sets damping factor to 5 (Note: Damping factor only applies to wind reading.)
 SET10nnnn Set output interval. Sets the time interval between measurements in one millisecond increments. Lower values increase power consumption when continuous measurements are taken. Default is 1000.
 0000-9999
 Where nnnn=
 Usage example:
 >SET101000 Sets output interval to 1000 milliseconds (1 second) (Note: If output interval is set too low, the ResponseONE will automatically calculate the minimum output interval.)

6.4 COMMAND DETAILS

COMMAND DESCRIPTION

SET01nn Enable RS-232 and RS-485 output modes. Default value is 04.
 Where nn=04
 08 Enable RS-485 output only
 16 Enable RS-485 half duplex
 24 Enable RS-485 full duplex
 Usage example:
 >SET0104 Enables RS-232 only.
 SET02n Set the serial output format. Default value is 2.
 Where n= 2 ASCII
 3 ASCII POLLED
 4 NMEA
 5 SDI-12
 Usage example:
 >SET022 Sets output to ASCII continuous. Note: If SDI-12 is selected, save settings (SET77) then power must be cycled off, then on again to operate properly. SDI-12 automatically sets baud rate to 1200 and disables RS-232 and RS-485.
 SET03nn Set the baud rate for RS-232/RS-485 serial communication. Default value is 96.
 Note: Baud rate must be the same as device connected to it.
 Where nn=12 1200 baud
 48 4800 baud
 96 9600 baud
 19 19200 baud
 38 38400 baud
 Usage example:
 >SET0338 Sets baud rate to 38400.
 SET04n Set wind speed units (ASCII, ASCII POLLED, NMEA and SDI-12). Default value is 4.
 Where n= 1 mph
 2 knots
 3 mph
 4 m/s
 Usage example:
 >SET044 Sets wind speed to m/s.
 SET05a Set sensor address for ASCII POLLED and SDI-12. Note: This is the address when

Continued on next page...

<p>SET12nnn Set sample count. The rate at which the sensor internally takes complete sonic wind samples is greater than 200 times per second. This command sets the number of internal samples used to calculate the median measurement result. Default is 16.</p> <p>Where nnn= 000-800 Usage example: >SET12016 Sets sample count to 16. More internal samples consume more power while providing greater immunity to conditions like turbulent high-speed wind. Fewer samples consume less power while providing less immunity to disruptive conditions. This command interacts with the OUTPUT INTERVAL setting. More samples may require a longer output interval.</p> <p>SET13n Set ASCII output format. Determines whether ASCII and ASCII POLLED serial outputs provide wind data in either Polar (speed and direction) or Cartesian (UV) form. Default is Polar.</p> <p>Where n= 0 Polar 1 Cartesian (UV)</p> <p>Usage example: >SET130 Sets output format to polar.</p> <p>SET14n Set units of temperature to Celsius or Fahrenheit. Default is Celsius.</p> <p>Where n= 0 Celsius 1 Fahrenheit</p> <p>Usage example: >SET140 Sets temperature units to Celsius.</p> <p>SET15n Set units of pressure to hPa or inHg. Default is hPa.</p> <p>Where n= 0 hPa (NMEA mode: units = Bar) 1 inHg</p> <p>Usage example: >SET150 Sets pressure units to hPa.</p> <p>SET16±nnn Set temperature offset. Value is x10. Default is 0.</p> <p>Where ±nnn= -100 to +100 Usage example: >SET16-012 Sets temperature offset to -1.2</p>	<p>SET17±nnn Set relative humidity offset. Value is x10. Default is 0.</p> <p>Where ±nnn= -100 to +100 Usage example: >SET17+008 Sets humidity offset to +0.8</p> <p>SET18±nnnn Set barometric pressure offset. Value is x10. Default is 0.</p> <p>Where ±nnnn= -5000 to +5000 Usage example: >SET18+1234 Sets pressure offset to +123.4</p> <p>SET27 Set tipping bucket count to zero. The maximum tipping bucket count is 65535. Tipping bucket count automatically rolls over to zero once 65535 maximum count is reached (65535 + 1 = 0).</p> <p>SET28n Enable tipping bucket output. Default value is 0. Where n= 0 Disable tipping bucket 1 Enable tipping bucket</p> <p>Usage example: >SET281 Enable tipping bucket count output.</p> <p>SET77 Save all settings to non-volatile memory. Any settings which have not been saved will be lost when power is removed. Saved settings are loaded at power up. This command may be used any time the sensor is in COMMAND MODE. Note: ResponseONE CONFIG program automatically sends this command when <Send Parameters> button is pressed.</p> <p>XX Returns the sensor to OPERATE MODE RPTV Report current settings ?? Display command list HELP Display command list</p>
----------------------------------------------------------------------------------------------------------------------------------------------------------------------------------------------------------------------------------------------------------------------------------------------------------------------------------------------------------------------------------------------------------------------------------------------------------------------------------------------------------------------------------------------------------------------------------------------------------------------------------------------------------------------------------------------------------------------------------------------------------------------------------------------------------------------------------------------------------------------------------------------------------------------------------------------------------------------------------------------------------------------------------------------------------------------------------------------------------------------------------------------------------------------------------------------------------------------------------------------------------------------------------------------------------------------------------------------------------------------------------------------------------------------------------------------------------------------------------------------------------------------------------------------------------------------------------------------------------------------------------------------------------------------------------------------------------------------	-----------------------------------------------------------------------------------------------------------------------------------------------------------------------------------------------------------------------------------------------------------------------------------------------------------------------------------------------------------------------------------------------------------------------------------------------------------------------------------------------------------------------------------------------------------------------------------------------------------------------------------------------------------------------------------------------------------------------------------------------------------------------------------------------------------------------------------------------------------------------------------------------------------------------------------------------------------------------------------------------------------------------------------------------------------------------------------------------------------------------------------------------------------------------------------------------------------------------------------------------------------------------------------------------------------------------------------------------------------------------------------------------------------

7.0 EXAMPLE SETTINGS

Suggested settings. Not all possible setting combinations are shown. The **ResponseONE CONFIG** program is recommended for changing setup parameters. See wiring diagrams for jumper settings.

7.1 FACTORY DEFAULT

RS-232: Enabled
RS-485 (output only): Enabled
Serial Output Format: ASCII
Output Interval: 1000
Sample Count: 100

7.2 MINIMUM POWER

RS-232: Enabled
RS-485: Disabled
Serial Output Format: ASCII
Output Interval: 1000
Sample Count: 16

7.3 HIGH WINDS

Output Delay: 1000
Sample Count: 200

AVERAGE CURRENT DRAW

Output Format	Output Interval	Sample Count	Baud Rate (bps)	Average Current Draw (mA)
SDI-12 (polled)	5 minutes	16	1200	5.8
	5 minutes	100		5.8
	5 minutes	200		5.8
ASCII	1 second	16	9600	10.2
	1 second	100		22.1
	1.07 second	200		33.0
ASCII Polled	5 minutes	16	9600	7.6
	5 minutes	100		7.6
	5 minutes	200		7.6
NMEA	1 second	16	4800	9.4
	1 second	100		21.8
	1 second	200		32.7

8.0 EMC COMPLIANCE

This device complies with Part 15 of the FCC Rules. Operation is subject to the following two conditions: (1) this device may not cause harmful interference, and (2) this device must accept any interference received, including interference that may cause undesired operation.

This equipment has been tested and found to comply with the limits for a Class A digital device, pursuant to part 15 of the FCC Rules. These limits are designed to provide reasonable protection against harmful interference when the equipment is operated in a commercial environment. This equipment generates, uses, and can radiate radio frequency energy and, if not installed and used in accordance with the instruction manual, may cause harmful interference to radio communications. Operation of this equipment in a residential area is likely to cause harmful interference in which case the user will be required to correct the interference at his own expense.

This ISM device complies with Canadian ICES-001.
Cet appareil ISM est conforme à la norme NMB-001 du Canada.

EN55011/CISPR 11, Group 1, Class B device.

Class B equipment is suitable for use in domestic establishments and in establishments directly connected to a low voltage power supply network which supplies buildings used for domestic purposes.

9.0 WARRANTY

This product is warranted to be free of defects in materials and construction for a period of 12 months from date of initial purchase. Liability is limited to repair or replacement of the defective item. A copy of the warranty policy may be obtained from R. M. Young Company.

10.0 CE COMPLIANCE

This product has been tested and complies with European CE requirements for the EMC Directive. Please note that shielded cable must be used.

APPENDIX A: WIRING CONNECTIONS

Figure A1: RS-232 SERIAL CONNECTION

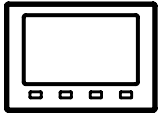

Serial Device

SETTINGS

Output Mode: RS-232
 Output Format: ASCII, ASCII POLLED, or NMEA
 Baud Rate: 1200, 4800, 9600, 19200 or 38400

Set connected device baud rate to match *ResponseONE*.
 1 start bit, 8 data bits, no parity, 1 stop bit, no flow control.

Use shielded cable. Connect cable shield to earth ground as shown.
 (Color code is for Young 18446 cable)

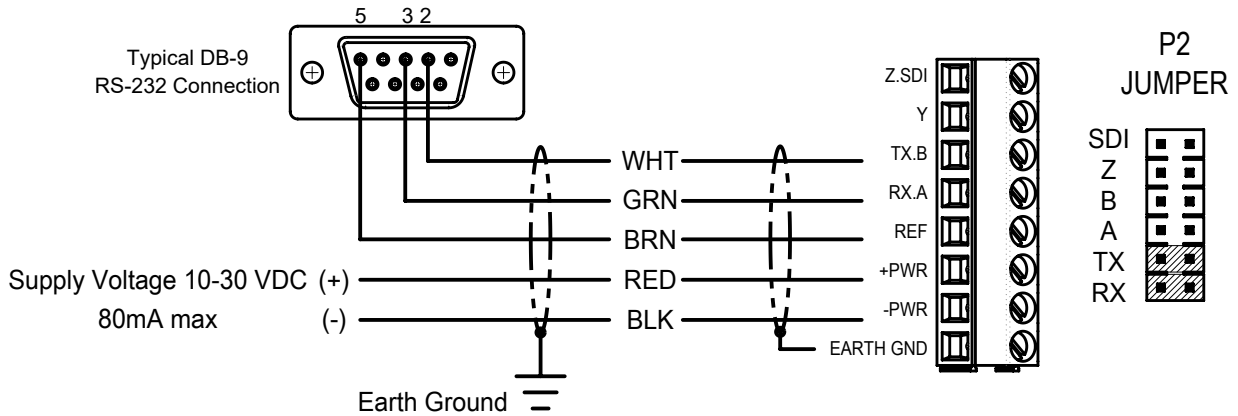
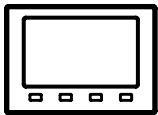

Figure A2: RS-485 / RS-422 SERIAL CONNECTION - FULL DUPLEX



Serial Device

SETTINGS

Output Mode: RS-485 Full Duplex
 Output Format: ASCII, ASCII POLLED, or NMEA
 Baud Rate: 1200, 4800, 9600, 19200 or 38400

Set serial device baud rate to match *ResponseONE*.
 1 start bit, 8 data bits, no parity, 1 stop bit, no flow control.

Use shielded cable. Connect cable shield to earth ground as shown.
 (Color code is for Young 18660 Cable)

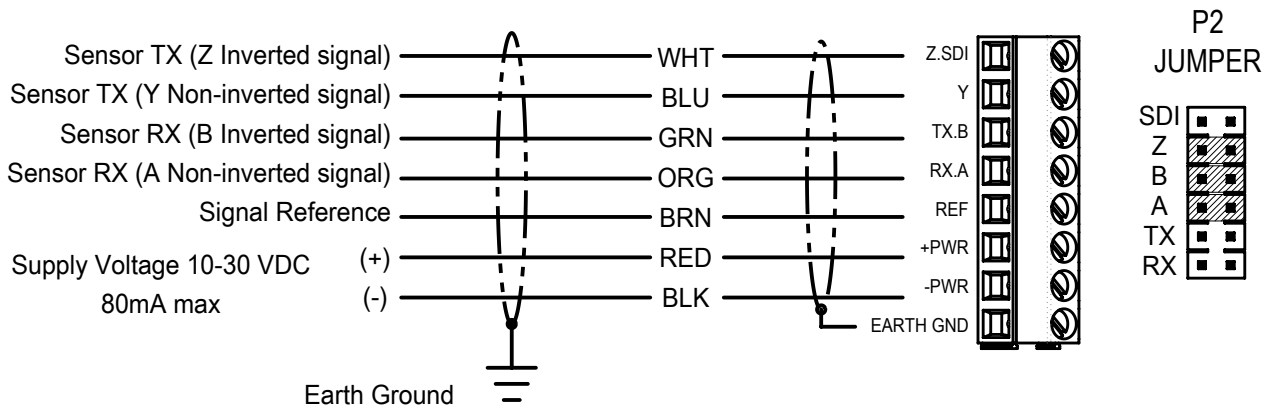

APPENDIX A: WIRING CONNECTIONS

Figure A3: RS-485 / RS-422 SERIAL CONNECTION - HALF DUPLEX

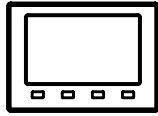

Serial Device

SETTINGS

Output Mode: RS-485 Half Duplex
 Output Format: ASCII, ASCII POLLED, or NMEA
 Baud Rate: 1200, 4800, 9600, 19200 or 38400

Set serial device baud rate to match *ResponseONE*.
 1 start bit, 8 data bits, no parity, 1 stop bit, no flow control.

Use shielded cable. Connect cable shield to earth ground as shown.
 (Color code is for Young 18446 Cable)

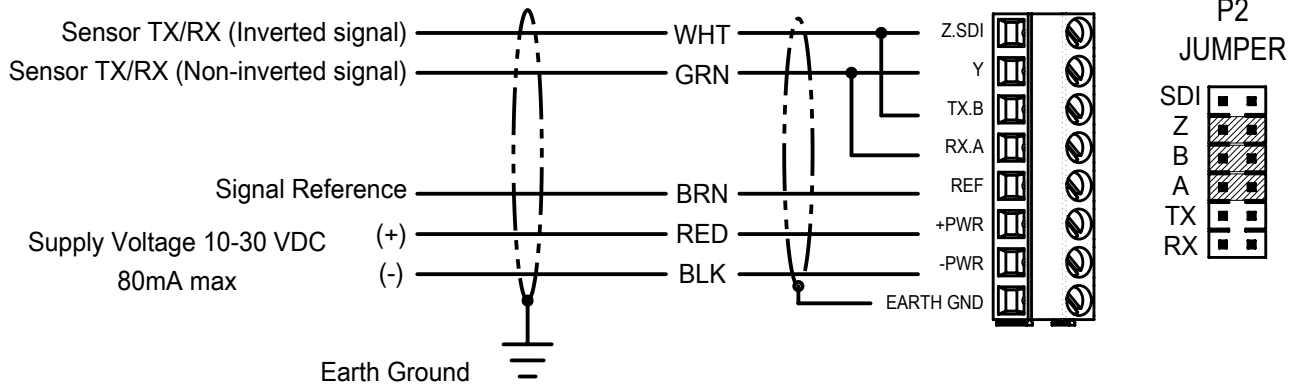
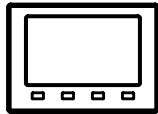

Figure A4: RS-485 / RS-422 SERIAL CONNECTION - OUTPUT ONLY



Serial Device

SETTINGS

Output Mode: RS-485 Output Only
 Output Format: ASCII, or NMEA
 Baud Rate: 1200, 4800, 9600, 19200 or 38400

Set serial device baud rate to match *ResponseONE*.
 1 start bit, 8 data bits, no parity, 1 stop bit, no flow control.

Use shielded cable. Connect cable shield to earth ground as shown.
 (Color code is for Young 18446 Cable)

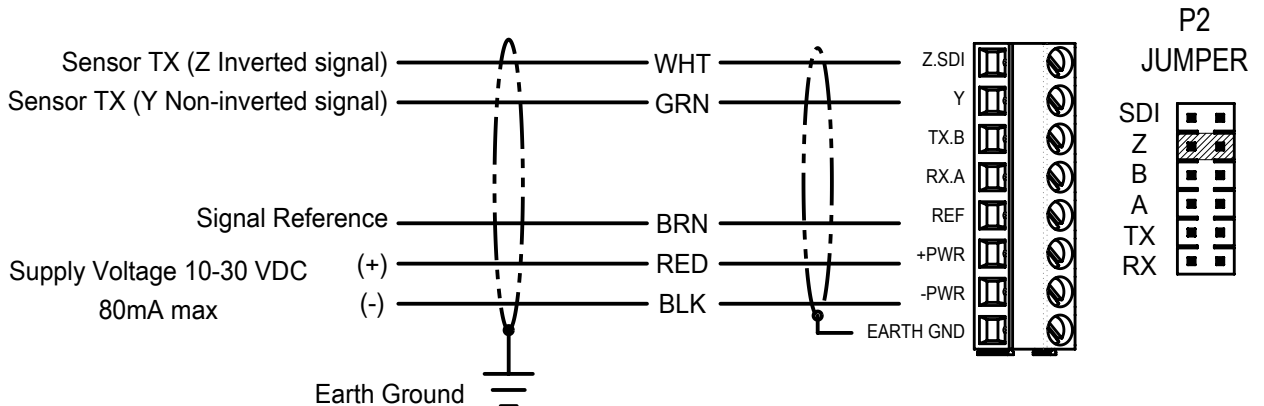

APPENDIX A: WIRING CONNECTIONS

Figure A5: SDI-12 SERIAL CONNECTION



Use shielded cable.
Connect cable shield to earth ground as shown.

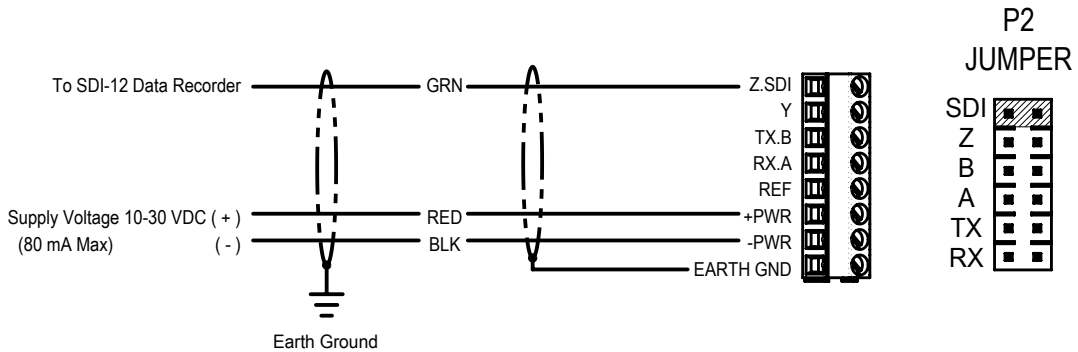
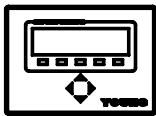

Figure A6: RS-485 SERIAL CONNECTION - FULL DUPLEX



SETTINGS

Output Mode: RS-485 Full Duplex
Output Format: ASCII, ASCII POLLED, or NMEA
Baud Rate: 1200, 4800, 9600, 19200 or 38400

Set 26800 Translator baud rate to match *ResponseONE*.

Use shielded cable. Connect cable shield to earth ground as shown.
(Color code is for Young 18660 cable)

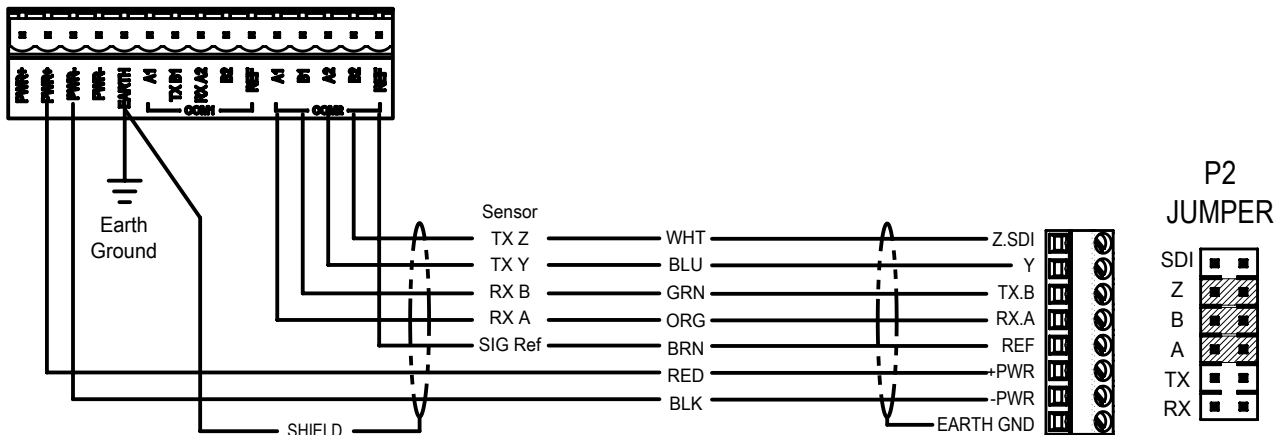

APPENDIX A: WIRING CONNECTIONS

Figure A7: TIPPING BUCKET RAIN GAUGE

(52202, 52203, OR EQUIVALENT)

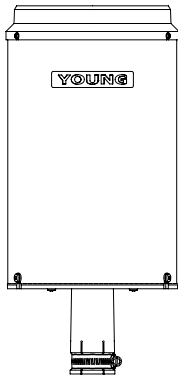

SETTINGS

Output Mode: RS-232, RS-485
Output Format: ASCII, ASCII POLLED, or SDI-12
Baud Rate: 1200, 4800, 9600, 19200 or 38400

Command: SET27 Set tipping bucket count to zero
SET28n n = 0 Disable Count
n = 1 Enable Count

Use 2 conductor cable. (Color code is for Young 18641 cable)

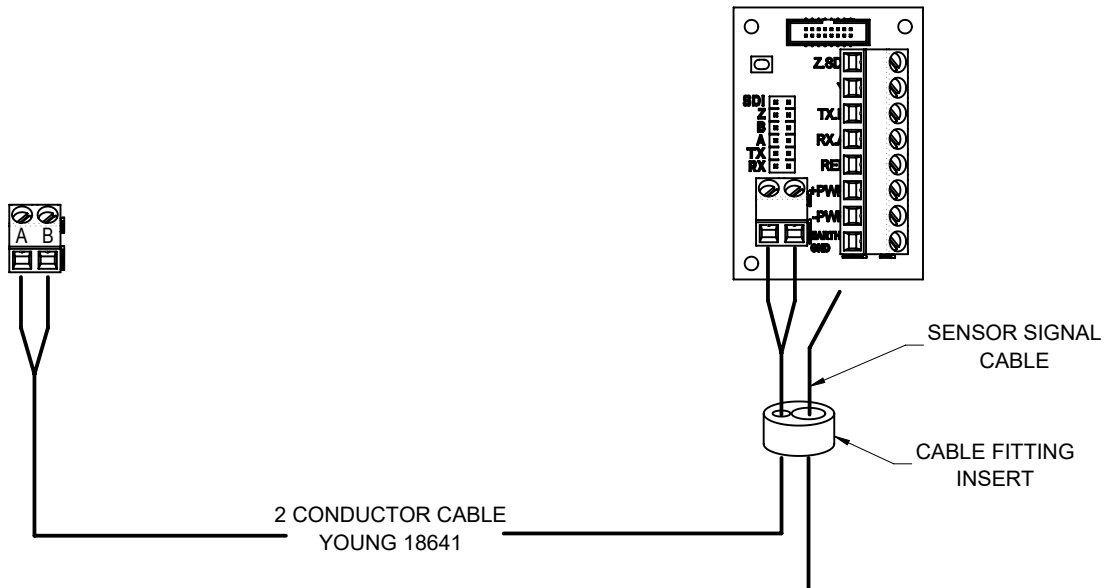
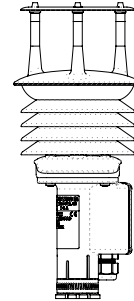

APPENDIX B: SENSOR ORIENTATION AND DIMENSIONS

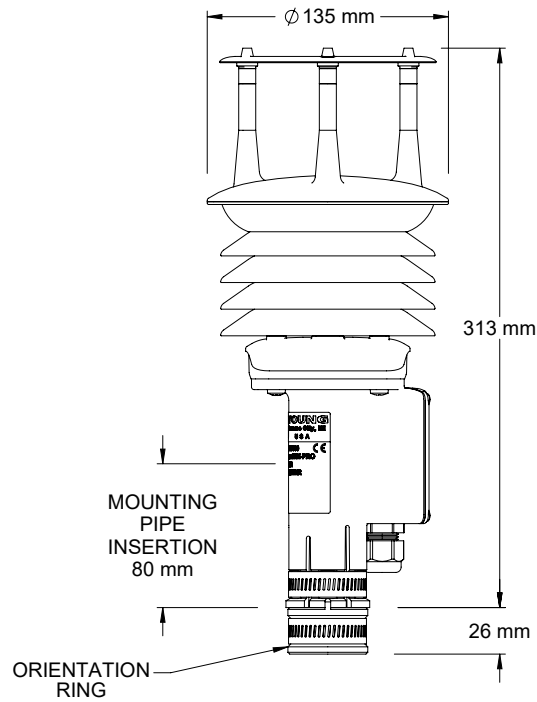
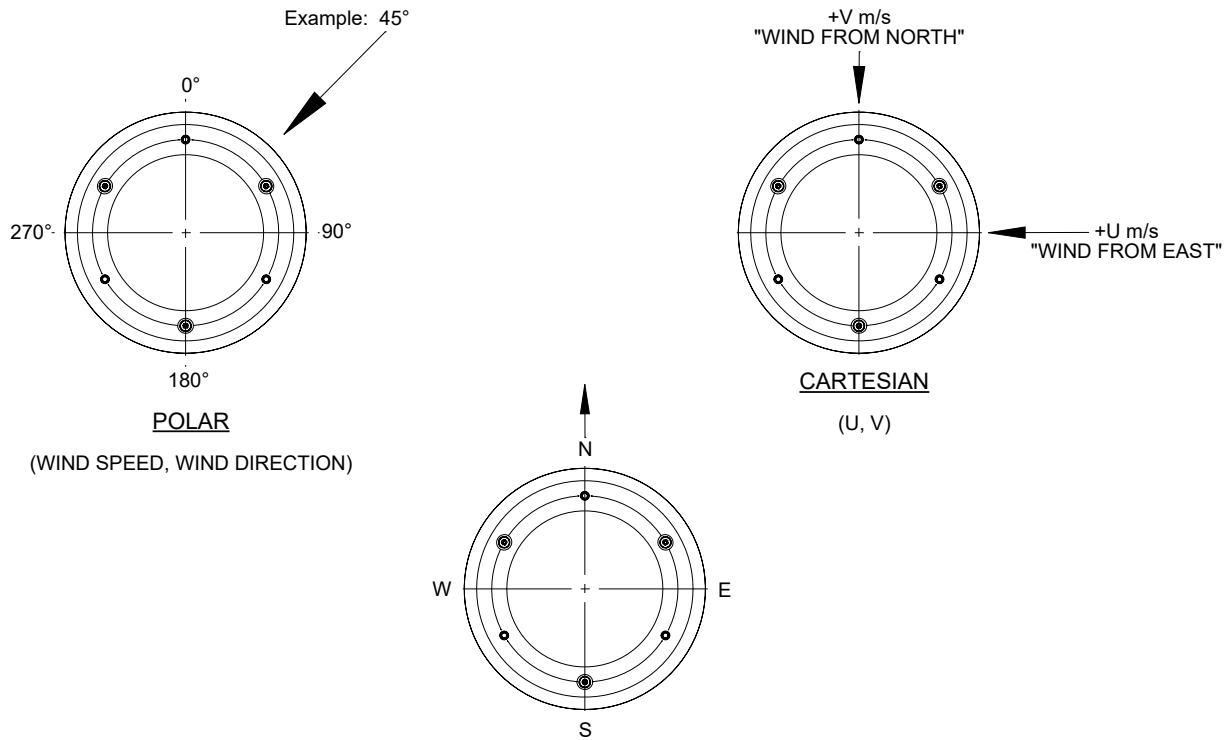

Note:
Install unit vertically as shown to avoid moisture damage to circuitry.

Mounting:
Standard 1-inch (IPS) pipe.
OD 1.32" (Ø 33 mm)

APPENDIX C: SERVICING FILTER & SENSOR MODULE

REMOVING FILTER AND SENSOR

1. Gently slide the chamber cover (on the bottom of the sensor) open to access the components inside.
2. Insert the filter wrench until you capture the sensor filter. Apply gentle pressure and rotate tool clockwise until the tabs on the filter engage the slots in the filter wrench.
3. Unscrew the filter from the sensor and remove tool and filter from sensor. If replacing the filter, dispose of the old one.
4. Insert the white dot end of the sensor stick tool (white dot facing away from the mounting post), into the sensor chamber. Engage the sensor stick until the latch of the tool is firmly engaged. Pull the sensor stick tool and sensor out of the chamber. Press the white dot on the tool to release and then remove the old sensor stick

REPLACING FILTER AND SENSOR

1. Insert the replacement sensor stick into the opposite, non-latch end of the sensor stick tool until well seated.
2. Guide the sensor into the chamber with the sensor stick's protective cover facing away from the mounting post. There is a device inside the top of the chamber which guides the sensor stick in the proper location. Press the sensor stick firmly into the pin header inside the sensor until fully seated. Gently remove the tool from the chamber, the sensor is retained by the friction of the pins.
3. Insert the filter into the end of the filter wrench, engaging the tabs with the tool slots. Guide tool and filter into sensor chamber and thread the filter into the sensor with firm pressure.
4. Remove filter wrench from sensor chamber and slide chamber cover back into location, protecting the internal components from solar radiation.



1. Open chamber cover and insert filter wrench



2. Unscrew filter and remove



3. Pull out sensor stick with sensor stick tool



Top: 93190 ResponseONE-Pro Filter Wrench

Bottom: 93191 ResponseONE-Pro Sensor Stick Tool

APPENDIX D: TROUBLESHOOTING

Problem	Solution
No Output	<ul style="list-style-type: none"> • Check input voltage at sensor (10 – 30 VDC). • Check wiring connections. • Verify serial settings (baud rate, 1 stop bit, 8 data bits, no parity, no flow control). • 'Acquire' the sensor with the ResponseONE CONFIG program (see section 6.2) and verify setup mode.
One-way communication	<ul style="list-style-type: none"> • Check wiring connections. • 'Acquire' the sensor with the ResponseONE CONFIG program (see section 6.2). • Change output mode to RS-485 full or half duplex, or RS-232.
Status codes other than 00 appear	<ul style="list-style-type: none"> • Status codes other than 00 (or 'A' in NMEA mode) mean there is an error. See 'Status Codes' section for details.
No response to poll command	<ul style="list-style-type: none"> • Check power supply. • Check wiring connections. • Verify serial settings (baud rate, 1 stop bit, 8 data bits, no parity, no flow control). • Verify sensor address (if the sensor's address is '0', then the poll command is '0M!' in SDI-12 mode and 'M0!' in ASCII Polled mode.). • 'Acquire' the sensor with the ResponseONE CONFIG program (see section 6.2) and verify setup mode.
Direction is incorrect	<ul style="list-style-type: none"> • 'Acquire' the sensor with the ResponseONE CONFIG program (see section 6.2) and verify settings. Set the wind direction offset if needed (default is 0000).
Tipping Bucket input not counting	<ul style="list-style-type: none"> • Check wiring. • Verify tipping bucket count output is enabled. • Verify proper operation of the tipping bucket.

Status codes for ASCII output are hex values added together before output (a status code of 0C would be a code of 08 and 04). NMEA only allows for 'acceptable' or 'void' data.

Status Code	Meaning
00	Valid data
01	Transducer path A blocked or dirty, clear blockage and clean transducers
02	Transducer path B blocked or dirty, clear blockage and clean transducers
04	Transducer path C blocked or dirty, clear blockage and clean transducers
08	Temperature/Relative Humidity Error
A	NMEA data acceptable (NMEA wind data only)
V	NMEA data void (NMEA wind data only)