



**INSTRUCTIONS**  
**MODEL 61402L**  
**BAROMETRIC PRESSURE SENSOR**

**CE**



## 1.0 SPECIFICATIONS

|   |  |                |   |
|---|--|----------------|---|
| Pressure  | 500 to 1100 hPa standard range                           | Output Rate    | 1.8 Hz (max) to 1 per minute  |
| Digital Accuracy*   | 0.2 hPa (25°C)<br>0.3 hPa (-40°C to +60°C)               | Current Output | 4 to 20 mA or 0 to 20 mA<br>12-bit resolution (1 in 4000)<br>Selectable pressure range: 500 to 1100 hPa (standard)                                    |
| Analog Accuracy**   | 0.05% of analog pressure range                           | Serial Output  | Full-duplex RS-232<br>Half-duplex RS-485<br>SDI-12<br>1200 to 38400 baud<br>Continuous ASCII text<br>Polled ASCII text<br>NMEA<br>0.01 hPa resolution |
| Analog Temperature Dependence**   | 0.0017% of analog pressure range per °C (25°C reference) | Supply Voltage | 7 to 30 VDC<br>25 mA max (4-20 or 0-20 mA mode)<br>1.5 mA max in SDI-12 mode<br>8.5 mA (RS-232 or RS-485)   |
| Long Term Stability:  | 0.08% FS per year  | Case           | Fiber-reinforced thermoplastic  |
| * Defined as $\pm 1$ standard deviation from NIST-traceable pressure reference in clean, dry air. Includes non-linearity, hysteresis, repeatability, and calibration uncertainty.               |  | Weight         | 44 g (1.5 oz)   |
| ** Defined as $\pm 1$ standard deviation from ideal analog output. Total analog output accuracy is the root sum square of digital accuracy, analog accuracy, and analog temperature dependence. |  |                |   |

### R.M. YOUNG COMPANY

2801 AERO PARK DRIVE, TRAVERSE CITY, MICHIGAN 49686, USA

TEL: (231) 946-3980 FAX: (231) 946-4772

PN: 61402L-90  
REV: A040819

## 2.0 INTRODUCTION

MODEL 61402L Barometric Pressure Sensor is a versatile electronic barometer featuring high accuracy, low power, wide operating temperature range, and calibrated 4-20 mA output, with SDI-12 and RS-232/485 serial data I/O.

The 4-20 mA output and RS-485 serial I/O make the 61402L ideal for commercial and industrial applications that commonly use these signals.

Full scale current output may be set to span any portion of the 500 to 1100 hPa operating range. Serial output options include continuous or polled ASCII text output, NMEA marine output or SDI-12. The sensor is supplied with the following standard configuration:

Current Output 4-20 mA = 500 to 1100 hPa  
 RS-232 Continuous ASCII text output 9600 baud  
 16 samples averaged  
 1.8 Hz update rate

## 3.0 INSTALLATION

The sensor operates over a temperature range of -40°C to +60°C and must remain dry. Electrical connections are made with the 5-position terminal plug included with the sensor. Jumper settings may be used to select operating options. Access jumpers by loosening two screws in the sensor enclosure and removing the cover. See last page for wiring details and jumper settings.

## 4.0 OPERATION

Operation begins approximately 1 second after power is applied. Output will appear after a delay determined by the number of samples averaged and the output rate. With default values (1.8 Hz output and 10 samples averaged), output begins after an initial 5 second delay then remains continuous at the 1.8 Hz rate. Parameters for output rate and number of samples averaged may be changed using software commands.

### 4.1 CURRENT OUTPUT

Calibrated 4-20 mA current output is always active. The connection scheme appears in the Wiring configurations section.

The current output scale may be mapped to any part of the 500 to 1100 hPa pressure range using the IOUT HI and IOUT LO software parameters. The standard setting maps 4 to 20 mA with 500 to 1100 hPa. With this setting:

$hPa = 37.5 * mA + 350$   
 Effective resolution is about 0.15 hPa

Greater effective resolution may be achieved by mapping the current output to a narrower range of pressure with the IOUT HI and IOUT LO parameters. For example, with IOUT LO set to 950 hPa and IOUT HI set to 1050 hPa:

$hPa = 6.25 * mA + 925$   
 Effective resolution is about 0.025 hPa

Please see section 4.3 below for details on changing the IOUT HI and LO parameters.

### 4.2 SERIAL OUTPUT

The 61402L may be configured for full-duplex RS-232, half-duplex RS-485, or SDI-12 by using the lower jumper pair. In addition, the upper jumpers must be set as follows:

| Lower  | Upper    | Output                |
|--------|----------|-----------------------|
| RS-232 | (A,B,C)  | Continuous ASCII Text |
| RS-485 | (B,C)    | Polled ASCII Text     |
| SDI-12 | (C only) | SDI-12                |

Standard baud rate is 9600 but several baud rates between 1200 and 38400 are available.

SDI-12 baud rate is fixed at 1200.

| Format                           | Description  |
|----------------------------------|--|
| Continuous ASCII Text (standard) | 9600 baud<br>16 sample average<br>1.8 Hz output      |
| Polled ASCII Text                | 9600 baud<br>10 sample average<br>Output when polled |
| Marine NMEA                      | 4800 baud<br>10 sample average<br>1 Hz output        |
| SDI-12                           | 1200 baud  |
| Software                         | Output parameters determined by software settings    |

See wiring configurations for more information.

In POLLED ASCII mode, the unit sends data only after receiving a poll command. The poll command is Ma! where 'a' is the address value. The standard address is '0' (ASCII 48) for a poll command of M0! Please see section 4.3 for details on changing the poll address.

Upon receiving a properly addressed poll command, the unit immediately sends data.

### 4.3 SOFTWARE COMMANDS

Software commands sent via serial communication may be used to set operational parameters. The sensor must be configured for serial communication and connected to a PC or other compatible device using a program like HyperTerm.

**New settings are stored in temporary memory and must be burned to flash with command CMD420 to be retained.**

Note that all P1 jumpers (A, B, C) must be removed for SOFTWARE format to change baud rate, sample average count, and output rate parameters.

Although the sensor may receive commands at any time, measurement output may be paused by sending three ESC (ASCII 27) characters or CMD300 1. While paused, COMMAND mode is indicated by a ">" prompt. All commands must be terminated with a carriage return CR (ASCII 13).

Use "?" to list available commands as shown below.

>>

YOUNG 61402L SERIES BAROMETER

```
-----
CMD100 n  OUTPUT PERIOD (0-60 sec)
CMD105 n  AVG SAMPLE COUNT (0-32)
CMD110 n  OUTPUT FORMAT
          1=ASCII 2=POLLED 3=NMEA 4=RAN 5=DIAG
CMD120 n  MULTIPLIER (10000 = 1.0000)
CMD125 n  OFFSET (hPa x 100)
CMD130 n  SEA LEVEL CORRECTION (hPa x 100)
CMD140 n  IOUT RANGE HI (500-1100)
CMD142 n  IOUT RANGE LO (500-1100)
CMD144 n  IOUT SCALE (1=0-20mA 4=4-20mA)
CMD150 c  POLL ADDR CHAR
CMD160 n  BAUD RATE (38400,19200,9600,4800,2400,1200)
CMD300 n  1=STOP, 2=RUN
CMD310 n  FORCE IOUT (0-20000 FULL SCALE)
CMD400 n  1=REPORT TEXT, 2=REPORT CODE ONLY
CMD410    GET CAL TABLE
CMD420    STORE SETUP PARAMETERS
```

>

**CMD100 n** sets output period in seconds. When set to zero, the output rate is 1.8 per second.

**CMD105 n** sets the average sample count. Higher sample count yields more stable readings but will lengthen the startup delay.

**CMD110 n** sets output format.

**CMD120 n** sets the output multiplier. 10000 represents 1.0000

**CMD125 n** sets the output offset in hPa x 100

**CMD130 n** sets the sea level correction in hPa x 100

$$= [P_{unadjust} * (Mult / 10000)] + [(Offset / 100) + (Correction_{Sea Level} / 100)]$$

**CMD140 n** sets the IOUT Pressure Range HI

**CMD142 n** sets the IOUT Pressure Range LO IOUT Pressure Range HI must be greater than IOUT Pressure Range LO

**CMD144 n** sets the IOUT Scale:  
1 = 0 to 20mA, or 4 = 4 to 20 mA.

**CMD150 c** sets the poll address character for ASCII and SDI-12 modes. Any ASCII character from '0' (ASCII 48) to 'z' (ASCII 122) may be used. For SDI-12 limit the characters from 0 to 9.

**CMD160 n** sets the baud rate. Acceptable values are 38400, 9600, 4800, 2400, and 1200. Note that the baud rate change occurs immediately after the command is received. Therefore, in order to continue communicating, the serial communication program that issued the command must also change to match.

**CMD300 n** causes the sensor to pause or resume measurement. 1 = Stop, 2 = Run.

**CMD400 n** causes the sensor to issue a report summarizing parameter settings.  
1 = Text (parameter values and labels)  
2 = Code Only (parameter values only).

**CMD420** burns the current parameter settings to flash memory. This step **must** take place to retain changes to settings otherwise parameters will revert to previous values at the next power up.

## 4.4 SDI-12 COMMANDS

SDI-12 stands for serial data interface at 1200 baud. It is often used to interface battery powered data recorders with microprocessor based devices designed for environmental data acquisition. SDI-12 is used typically when low power is a concern. The SDI-12 device normally remains in a low power, standby state until it is polled at which time a measurement is sent. SDI-12 can effectively address multiple sensors on the same cable.

Model 61402L uses the SDI-12 (V1.4) serial communication protocol to initiate measurements and set sensor operation parameters. The default sensor address is 0 (zero), and can be changed to any valid single-character value if needed. Additional details about the SDI-12 protocol may be found at [www.sdi-12.org](http://www.sdi-12.org).

After initial power-up with 12 VDC, the sensor is in a low-power standby state with a quiescent current of 1.60 mA. A valid and properly addressed SDI-12 command wakes the sensor to initiate a measurement, set or check operating parameters. After command processing has finished, the sensor returns to the low-power standby state.

SDI-12 'M' or 'C' commands initiate a measurement. The sensor response message indicates the maximum time needed before the measurement is ready, and data values will be available. The maximum time ranges from 1 to 5 seconds depending on the Sample Count.

If an 'M' command initiates a measurement, the sensor sends a Service Request when the measurement is ready to be retrieved. When the polling device receives the Service Request it then sends a 'D' command to request measurement results from the sensor. With 'C' commands, no Service Request is sent, and the polling device must wait the full delay time before sending the 'D' command to request the measurement.

SDI-12 Measurement commands and responses:

| COMMAND  | RESPONSE                    | DESCRIPTION                                     |
|----------|-----------------------------|---|
| aM!      | atfts<CR><LF>               | Take a measurement                              |
| aMC!     | atfts<CR><LF>               | Take a measurement with CRC checksum            |
| aC!      | atftss<CR><LF>              | Take a concurrent measurement                   |
| aCC!     | atftss<CR><LF>              | Take a concurrent measurement with CRC checksum |
| aD0!     | a+tftt.t+bbbb.b<CR><CR><LF> |   |
| where:   |                             |   |
| a        | =                           | Sensor address                                  |
| tft      | =                           | Delay time (seconds)                            |
| s/ss     | =                           | Number of samples to collect                    |
| tft.t    | =                           | Temperature (selected units)                    |
| bbbb.b   | =                           | Barometric Pressure (selected units)            |
| <CRC>    | =                           | CRC checksum (only where requested)             |
| <CR><LF> | =                           | Carriage return, line feed (ASCII 13, 10)       |

SDI-12 NON-MEASUREMENT COMMANDS:

The SDI-12 protocol includes standard commands for identifying the sensor and changing its address.

| CMD  | RESPONSE                            | DESCRIPTION   |
|------|-------------------------------------|---|
| ?!   | a<CR><LF>                           | Address Query   |
| a!   | a<CR><LF>                           | Acknowledge Active  |
| all  | a13 YOUNG C092000 vvvnnnnnn<CR><LF> | Send Identification: vvv = Firmware Version<br>nnnnnn = Serial Number |
| aAb! | b<CR><LF>                           | Change Address:<br>a = Sensor address<br>b = New sensor address       |
| aV!  | a0000<CR><LF>                       | Start Verification  |

EXTENDED COMMANDS:

The SDI-12 command set may be customized with Extended Commands to accommodate manufacturer settings and other functions. Extended Commands are listed below. Where two responses are shown, one is for a valid command, the other is for an invalid (ERR) command.

| COMMAND   | RESPONSE  | DESCRIPTION  |
|-----------|---|--|
| aXB!      | aXB, OK<CR><LF>                                   | Save parameter settings to flash.<br>Cycle power after saving parameters.  |
| aXP!      | aXP, V=v, OP=o, ASC=s, MP=m, OS=op, SC=sc<CR><LF> | v = voltage (12.0 = 12.0 volts)<br>o =<br>s =<br>m =<br>op = offset (hPa x 10)<br>sc = sea level correction (hPa x 10) |
| aXC±nnnn! | aXC, SC=±nnnn<CR><LF>                             | Sea Level Correction (-5000 to +5000 hPa)  |
| aXF±nnnn! | aXF, OP=±nnnn<CR><LF>                             | Offset (-5000 to +5000 hPa)  |
| aXM       | aXM, M=nnnn<CR><LF>                               | Multiplier (10000 = 1.0000)  |
| aXO       | aXO, O=nn<CR><LF>                                 | Output Period (0 - 60)   |
| aXS       | aXS, S=nn<CR><LF>                                 | Sample Count (1 - 32)  |

## 5.0 MAINTENANCE

The MODEL 61402L barometer requires no regular maintenance. Periodic calibration certification, if required, is available from the factory.

## 6.0 WARRANTY

This product is warranted to be free of defects in materials and construction for a period of 12 months from date of initial purchase. Liability is limited to repair or replacement of defective item. A copy of the warranty policy may be obtained from R. M. Young Company.

## 7.0 EMC COMPLIANCE

This device complies with Part 15 of the FCC Rules. Operation is subject to the following two conditions: (1) this device may not cause harmful interference, and (2) this device must accept any interference received, including interference that may cause undesired operation.

This equipment has been tested and found to comply with the limits for a Class A digital device, pursuant to part 15 of the FCC Rules. These limits are designed to provide reasonable protection against harmful interference when the equipment is operated in a commercial environment. This equipment generates, uses, and can radiate radio frequency energy and, if not installed and used in accordance with the instruction manual, may cause harmful interference to radio communications. Operation of this equipment in a residential area is likely to cause harmful interference in which case the user will be required to correct the interference at his own expense.

This ISM device complies with Canadian ICES-001.

Cet appareil ISM est conforme à la norme NMB-001 du Canada. EN55011/CISPR 11, Group 1, Class B device.

Class B equipment is suitable for use in domestic establishments and in establishments directly connected to a low voltage power supply network which supplies buildings used for domestic purposes.

## 8.0 CE COMPLIANCE

This product has been tested and complies with European CE requirements for the EMC Directive. Please note that shielded cable must be used.

## WIRING CONFIGURATIONS

### CURRENT OUTPUT

$$\text{Maximum } I_{\text{OUT}} \text{ load resistor (ohms)} = \frac{(V_{\text{supply}} - 6)}{0.02}$$

EXAMPLE:

$$900 \text{ ohms max load resistor} = (24 \text{ V} - 6) / 0.02 \text{ A}$$

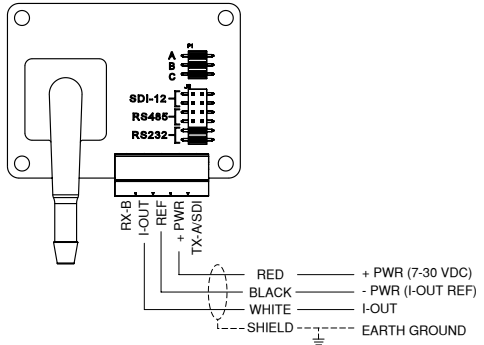

### RS-485 / RS-232 SERIAL OUTPUT

9600 BAUD  
 16 SAMPLE AVERAGE COUNT  
 1.8 HZ

EXAMPLE SERIAL OUTPUT STRING EXAMPLE:

CONTINUOUS  
 AND POLLED  
 ASCII OUTPUT <1000.00<CR><LF>  
 NMEA OUTPUT <\$WIXDR,P,1.00000,B,BARO\*73<CR><LF>

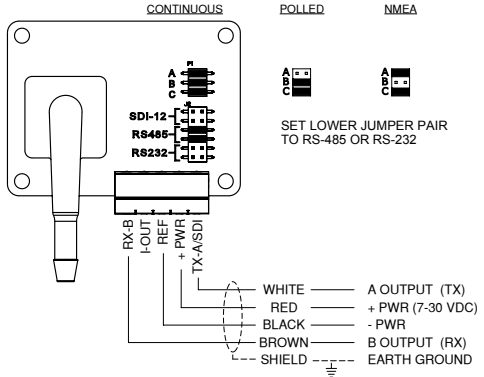

### SDI-12 OUTPUT CONFIGURATION

1200 BAUD

