



METEOROLOGICAL INSTRUMENTS

INSTRUCTIONS

**WIND SENTRY ANEMOMETER
MODEL 03102L**





**MODEL 03102L
WIND SENTRY ANEMOMETER
(WITH 4-20mA OUTPUTS)**



WIND SPEED SPECIFICATION SUMMARY

Range	0 to 50 m/s (112 mph) Gust Survival 60 m/s (134 mph)
Sensor	Ø 12 cm cup wheel assembly Ø 40 mm hemispherical cups
Turning Factor	75 cm (2.46 ft)
Distance Constant	2.3 m (7.5 ft.) for 63% recovery
Threshold Sensitivity	1.1 m/s (2.5 mph)
Transducer	Stationary coil 1300 Ohm nominal DC resistance
Output Signal	4-20 mA = 0-50 m/s

GENERAL

Power Requirement:	8 - 30 VDC
Operating Temperature:	-50 to 50°C (-58 to 122°F)

INTRODUCTION

The Wind Sentry Anemometer measures horizontal wind speed. The small size, simplicity, and corrosion resistant construction provide a professional quality instrument at a modest cost. The cup wheel shaft uses stainless steel precision instrument grade ball bearings which are lubricated with a wide temperature range high quality instrument oil. Standard bearings have light contacting seals to exclude contamination and help retain lubricant for longer service life.

Cup wheel rotation produces an AC sine wave voltage signal with frequency proportional to wind speed. Internal circuitry converts the raw signal to 4 to 20 mA current output over the specified 0 to 50 m/s wind speed range.

The sensor mounts on standard 1 inch pipe, outside diameter 34 mm (1.34") and is supplied with a cross arm and junction box for cable connections. Wind Sentry anemometers and wind vanes are available separately with similar mounting and junction box.

INITIAL CHECK-OUT

When the Wind Sentry is unpacked, check it carefully for any signs of shipping damage.

Place the cup wheel on the anemometer shaft and secure it by tightening the set screw on the side of the hub. The instrument is fully calibrated before shipment; however, it should be checked both mechanically and electrically before installation. The cup wheel should easily rotate 360° without friction.

INSTALLATION

Proper placement of the instrument is very important. Eddies from trees, buildings, or other structures can greatly influence wind speed and direction observations. To get meaningful data for most applications, locate the instrument well above or upwind of such obstructions. As a general rule, the air flow around a structure is disturbed to twice the height of the structure upwind, six times the height downwind, and twice the height of the structure above ground. For some applications it may not be practical or necessary to meet these requirements.

Grounding the Wind Sentry is vitally important. Without proper grounding, static electrical charge can build up during certain atmospheric conditions and discharge through the transducers. This discharge may cause erroneous signals or transducer failure. To direct the discharge away from the transducers, housings in which the transducers are mounted are made with a special anti-static plastic. It is important that the mounting post be connected to a good earth ground. There are two ways this may be accomplished. First, the Wind Sentry may be mounted on a metal pipe which is connected to earth ground. The mounting pipe should not be painted where the Wind Sentry is mounted. Towers or masts set in concrete should be connected to one or more grounding rods. If it is difficult to ground the mounting post in this manner, the following method should be used. Inside the junction box the screw labeled EARTH GND is connected to the anti-static housings. This terminal should be connected to an earth ground (Refer to wiring diagram).

To install the Wind Sentry, follow these steps:

1. MOUNT WIND SENTRY
 - a) Connect sensor cable to Wind Sentry junction box.
 - b) Place Wind Sentry on mounting post.
 - c) Tighten mounting post band clamp.
 - d) Connect sensor cable to measuring instrument as shown in manual.

CALIBRATION

The Wind Sentry is fully calibrated before shipment and should require no adjustments. Recalibration may be necessary after some maintenance operations. Periodic calibration checks are desirable and may be necessary where the instrument is used in programs which require auditing of sensor performance.

Wind speed calibration is determined by the cup wheel turning factor and the output characteristics of the transducer. The calibration formula relating cup wheel rpm to wind speed is shown below. Standard accuracy is ± 0.5 m/s (1.1 mph). For greater accuracy, the sensor must be individually calibrated in comparison with a wind speed standard. Contact the factory or your supplier to schedule a NIST (National Institute of Standards & Technology) traceable wind tunnel calibration in our facility.

To calibrate wind system electronics, temporarily remove the cup wheel and connect a Model 18802 Anemometer Drive to the cup wheel shaft. Apply the calibration formula to the motor rpm and adjust the signal conditioning electronics for proper value. For example, with the cup wheel shaft turning at 1800 rpm, adjust the indicator to display 22.7 meters per second. ($0.01250 \times 1800 + 0.2 = 22.7$)

CALIBRATION FORMULAS

Model 03102L Wind Sentry Anemometer

WIND SPEED	vs	CUP WHEEL RPM
m/s	=	$(0.01250 \times \text{rpm}) + 0.2$
knots	=	$(0.02427 \times \text{rpm}) + 0.4$
mph	=	$(0.02795 \times \text{rpm}) + 0.4$
km/h	=	$(0.04499 \times \text{rpm}) + 0.7$
WIND SPEED	vs	mA OUTPUT
m/s	=	$((\text{mA} - 4.06) \times 3.125) + 0.2$
knots	=	$((\text{mA} - 4.05) \times 6.0745) + 0.4$
mph	=	$((\text{mA} - 4.05) \times 6.9904) + 0.4$
km/h	=	$((\text{mA} - 4.06) \times 11.2500) + 0.7$

MAINTENANCE

Given proper care, the Wind Sentry should provide years of service. Because of its durable, corrosion resistant construction, the instrument requires little maintenance. The only components likely to require replacement due to normal wear are the precision ball bearings. Replacement of these components should only be performed by a qualified instrument technician. If service facilities are not available, return the instrument to the factory. Refer to the accompanying drawings to become familiar with part names and locations. Maximum torque on all set screws is 80 oz-in.

ANEMOMETER FLANGE BEARING REPLACEMENT

If anemometer bearings become noisy or wind speed threshold increases above an acceptable level, replace the bearings. Check bearing condition by hanging an ordinary paper clip (0.5 gm) on the outside edge of one cup while the instrument is held in a horizontal position. The cup should rotate downward. Failure to rotate due to the weight of the paper clip indicates anemometer bearings need replacement. Repeat this test at different positions to check full bearing rotation. Replace bearings as follows:

1. REMOVE BEARINGS
 - a) Loosen set screw on side of cup wheel hub. Remove cup wheel.
 - b) Remove three screws which hold two sections of main housing.
 - c) Carefully separate upper and lower housing. Remove coil transducer assembly from upper housing. Do not disconnect from circuit board.
 - d) Loosen screw and remove ring magnet on end of shaft inside upper housing.
 - e) Slide shaft and skirt assembly out of both upper and lower bearings.
 - f) Using knife blade under bearing flange, carefully remove upper bearing.
 - g) Using a pencil, gently push out lower bearing from above.
2. INSTALL NEW BEARINGS
 - a) Insert new upper bearing. Use care not to apply excessive pressure.
 - b) Slide cup wheel shaft through upper bearing.
 - c) Slide lower bearing on shaft inside upper housing.
 - d) Using ring magnet assembly, push lower bearing into its seat in upper housing.
 - e) Secure ring magnet to shaft using screw removed in step 1d. Use a small amount of sealant on screw to prevent it from loosening.
 - f) Join two housing sections. Secure using three screws removed in step 1b.
 - g) Place cup wheel on shaft. Tighten set screw on side of hub. Do not exceed 80 oz-in torque.

EMC COMPLIANCE

This device complies with Part 15 of the FCC Rules. Operation is subject to the following two conditions: (1) this device may not cause harmful interference, and (2) this device must accept any interference received, including interference that may cause undesired operation.

This equipment has been tested and found to comply with the limits for a Class A digital device, pursuant to part 15 of the FCC Rules. These limits are designed to provide reasonable protection against harmful interference when the equipment is operated in a commercial environment. This equipment generates, uses, and can radiate radio frequency energy and, if not installed and used in accordance with the instruction manual, may cause harmful interference to radio communications. Operation of this equipment in a residential area is likely to cause harmful interference in which case the user will be required to correct the interference at his own expense.

This ISM device complies with Canadian ICES-001.
Cet appareil ISM est conforme à la norme NMB-001 du Canada.

EN55011/CISPR 11, Group 1, Class B device.
Class B equipment is suitable for use in domestic establishments and in establishments directly connected to a low voltage power supply network which supplies buildings used for domestic purposes.

Note:
Wind Sentry sensors with Line Driver Output may be disrupted by radiated RF interference at 240-300 MHz. To meet EMC Compliance, (2) YOUNG 18500 ferrite chokes must be installed on the cable, one near the sensor, and one near the recording instrument. (Each choke must have the cable pass through the center hole at least 2 times, creating 1 loop around the outside as shown below.)

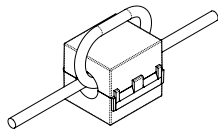

WARRANTY

This product is warranted to be free of defects in materials and construction for a period of 12 months from date of initial purchase. Liability is limited to repair or replacement of defective item. A copy of the warranty policy may be obtained from R. M. Young Company.

CE COMPLIANCE

This product has been tested and complies with European CE requirements for the EMC Directive. Please note that shielded cable must be used.



CABLE & WIRING DIAGRAM

MODEL 03102L WIND SENTRY ANEMOMETER

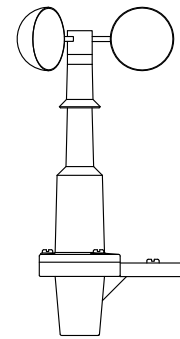
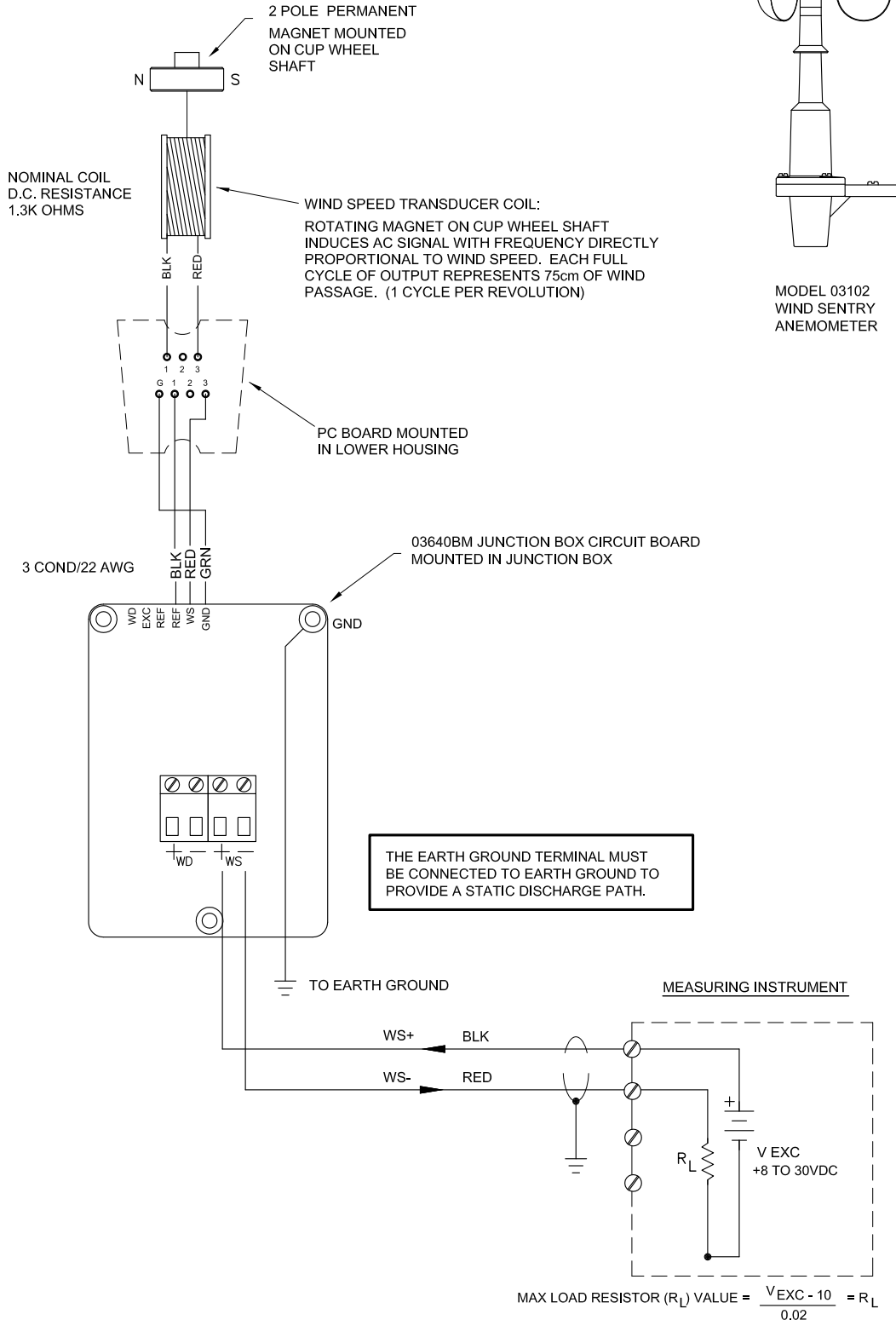

MODEL 03102
WIND SENTRY
ANEMOMETER



CIRCUIT DIAGRAM

MODEL 03102L WIND SENTRY ANEMOMETER
(03640BM WIND LINE DRIVER)

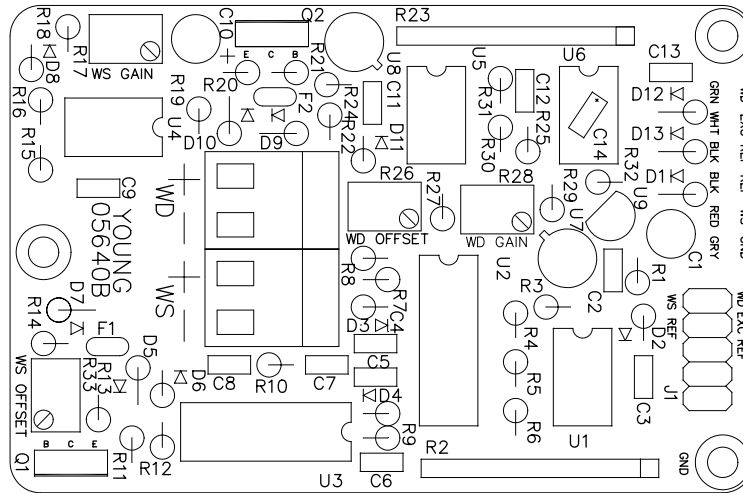

CIRCUIT SCHEMATICS

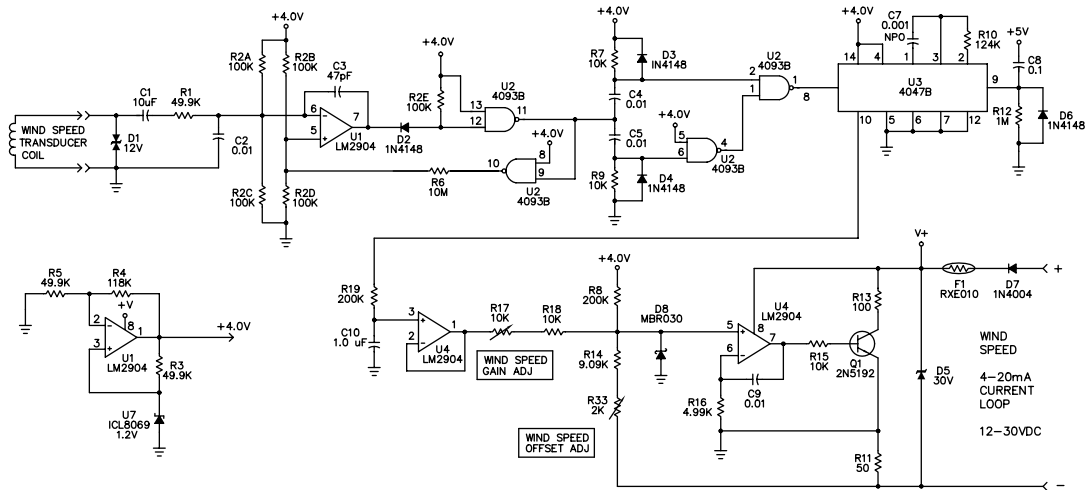



GENERAL ASSEMBLY & REPLACEMENT PARTS

MODEL 03102L WIND SENTRY ANEMOMETER

