



# METEOROLOGICAL INSTRUMENTS

## INSTRUCTIONS

**WIND SENTRY  
MODEL 03002L**





**MODEL 03002L**  
**WIND SENTRY**  
 (WITH 4-20mA OUTPUT)  
 INCLUDES MODELS 03102L & 03302L



**WIND SPEED SPECIFICATION SUMMARY**

Range	0 to 50 m/s (112 mph) Gust Survival 60 m/s (134 mph)
Sensor	12 cm diameter cup wheel assembly 40 mm diameter hemispherical cups
Turning Factor	75 cm (2.46 ft)
Distance Constant	2.3 m (7.5 ft.) for 63% recovery
Threshold Sensitivity	1.1 m/s (2.5 mph)
Transducer	Stationary coil, 1300 Ohm nominal DC resistance
Output Signal	4-20 mA = 0-50 m/s

**WIND DIRECTION (AZIMUTH) SPECIFICATION SUMMARY**

Range	360° mechanical, 352° electrical (8° open)
Sensor	Balanced vane, 16 cm (6.3 in) turning rad.
Damping Ratio	0.2
Delay Distance	0.5 m (1.6 ft) for 50% recovery
Threshold Sensitivity	1.3 m/s (2.9 mph) at 10° displacement 1.9 m/s (4.2 mph) at 5° displacement
Transducer	Precision conductive plastic potentiometer, 10K ohm resistance (±20%), 1.0% linearity, life expectancy 50 million revolutions, rated 1 watt at 40°C, 0 watts at 125°C
Output Signal	4 to 20 mA = 0 to 360°

**GENERAL**

Power Requirement:	8 - 30 VDC (5mA @ 12 VDC)
Operating Temperature:	-50 to 50°C (-58 to 122°F)

**INTRODUCTION**

The Wind Sentry Anemometer and Vane measure horizontal wind speed and wind direction. The small size, simplicity, and corrosion resistant construction provide a professional quality instrument at a modest cost. The cup wheel and vane shafts use stainless steel precision instrument grade ball bearings which are lubricated with a wide temperature range high quality instrument oil. Standard bearings have light contacting seals to exclude contamination and help retain lubricant for longer service life.

Cup wheel rotation produces an AC sine wave voltage signal with frequency proportional to wind speed. Internal circuitry converts the raw signal to 4 to 20 mA current output over the specified 0 to 50 m/s wind speed range.

Vane position is sensed by a 10K ohm precision conductive plastic potentiometer. This signal is also converted to 4 to 20 mA current output.

The sensor mounts on standard 1 inch pipe, outside diameter 34 mm (1.34") and is supplied with a cross arm and junction box for cable connections. Wind Sentry anemometers and wind vanes are available separately with similar mounting and junction box.

**INITIAL CHECK-OUT**

When the Wind Sentry is unpacked, check it carefully for any signs of shipping damage.

Place the cup wheel on the anemometer shaft and secure it by tightening the set screw on the side of the hub. The instrument is aligned, balanced, and fully calibrated before shipment; however, it should be checked both mechanically and electrically before installation. The vane and cup wheel should easily rotate 360° without friction. Check vane balance by holding the instrument so the vane surface is horizontal. It should have near-neutral torque without any particular tendency to rotate. A slight imbalance will not degrade performance.

**INSTALLATION**

Proper placement of the instrument is very important. Eddies from trees, buildings, or other structures can greatly influence wind speed and direction observations. To get meaningful data for most applications, locate the instrument well above or upwind of such obstructions. As a general rule, the air flow around a structure is disturbed to twice the height of the structure upwind, six times the height downwind, and twice the height of the structure above ground. For some applications it may not be practical or necessary to meet these requirements.

Grounding the Wind Sentry is vitally important. Without proper grounding, static electrical charge can build up during certain atmospheric conditions and discharge through the transducers. This discharge may cause erroneous signals or transducer failure. To direct the discharge away from the transducers, housings in which the transducers are mounted are made with a special anti-static plastic. It is important that the mounting post be connected to a good earth ground. There are two ways this may be accomplished. First, the Wind Sentry may be mounted on a metal pipe which is connected to earth ground. The mounting pipe should not be painted where the Wind Sentry is mounted. Towers or masts set in concrete should be connected to one or more grounding rods. If it is difficult to ground the mounting post in this manner, the following method should be used. Inside the junction box the screw labeled EARTH GND is connected to the anti-static housings. This terminal should be connected to an earth ground (Refer to wiring diagram).

Vane alignment is most easily done with two people; one to adjust the instrument position and the other to observe the indicating device. When anemometer and vane are mounted on the same cross arm (Model 03002), the azimuth potentiometer has been aligned at the factory such that the mounting cross arm should be oriented North-South with the vane on the North end.

To install the Wind Sentry, follow these steps:

1. MOUNT WIND SENTRY
  - a) Connect sensor cable to Wind Sentry junction box.
  - b) Place Wind Sentry on mounting post. Do Not tighten band clamp yet.
  - c) Connect sensor cable to indicator.
2. ALIGN VANE
  - a) Select a known azimuth reference point on the horizon.
  - b) Sighting down vane center line, point counterweight at reference point on horizon.
  - c) While holding vane in position, slowly turn base until indicator displays proper value.
  - d) Tighten mounting post band clamp.

## CALIBRATION

The Wind Sentry is fully calibrated before shipment and should require no adjustments. Recalibration may be necessary after some maintenance operations. Periodic calibration checks are desirable and may be necessary where the instrument is used in programs which require auditing of sensor performance.

For wind direction calibration, the following method can yield an accuracy of  $\pm 5^\circ$  or better if carefully done. Begin by connecting the instrument to a signal conditioning circuit which indicates wind direction value. This may be an indicator which displays wind direction values in angular degrees or simply a voltmeter monitoring the output. Hold or mount the instrument so the vane center of rotation is over the center of a sheet of paper which has  $30^\circ$  or  $45^\circ$  cross markings. Position the instrument so the mounting cross arm is oriented north-south with the vane on the north and the anemometer on the south. With the counterweight pointing directly at the anemometer the azimuth signal should correspond to  $180^\circ$  or due south. Looking from above, visually align the vane with each of the cross markings and observe the indicator display. It should correspond to vane position within  $5^\circ$ . If not, it may be necessary to adjust the relative position of the vane skirt and shaft. See step 3 in the MAINTENANCE section under potentiometer replacement.

It is important to note that while the sensor mechanically rotates through  $360^\circ$ , full scale wind direction signal from the signal conditioning occurs at  $352^\circ$ . The signal conditioning electronics must be adjusted accordingly. For example, in a circuit where 4 to 20 mA represents  $0^\circ$  to  $360^\circ$ , the output must be adjusted for 19.6 mA when the instrument is at  $352^\circ$  full scale.  $[(352^\circ/360^\circ \times 16 \text{ mA}) + 4 \text{ mA}]$

Wind speed calibration is determined by the cup wheel turning factor and the output characteristics of the transducer. The calibration formula relating cup wheel rpm to wind speed is shown below. Standard accuracy is  $\pm 0.5 \text{ m/s}$  (1.1 mph). For greater accuracy, the sensor must be individually calibrated in comparison with a wind speed standard. Contact the factory or your supplier to schedule a NIST (National Institute of Standards & Technology) traceable wind tunnel calibration in our facility.

To calibrate wind system electronics, temporarily remove the cup wheel and connect a Model 18802 Anemometer Drive to the cup wheel shaft. Apply the calibration formula to the motor rpm and adjust the signal conditioning electronics for proper value. For example, with the cup wheel shaft turning at 1800 rpm, adjust the indicator to display 22.7 meters per second.  $(0.01250 \times 1800 + 0.2 = 22.7)$

## CALIBRATION FORMULAS

### Model 03102L Wind Sentry Anemometer

WIND SPEED	vs	CUP WHEEL RPM
m/s	=	$(0.01250 \times \text{rpm}) + 0.2$
knots	=	$(0.02427 \times \text{rpm}) + 0.4$
mph	=	$(0.02795 \times \text{rpm}) + 0.4$
km/h	=	$(0.04499 \times \text{rpm}) + 0.7$

WIND SPEED	vs	mA OUTPUT
m/s	=	$(3.125 \times \text{mA}) - 12.5$
knots	=	$(6.075 \times \text{mA}) - 24.3$
mph	=	$(6.990 \times \text{mA}) - 28.0$
km/h	=	$(11.250 \times \text{mA}) - 45.0$

WIND DIRECTION	vs	mA OUTPUT
DEGREES	=	$(22.5 \times \text{mA}) - 90$

## MAINTENANCE

Given proper care, the Wind Sentry should provide years of service. Because of its durable, corrosion resistant construction, the instrument requires little maintenance. The only components likely to require replacement due to normal wear are the precision ball bearings and the azimuth potentiometer. Replacement of these components should only be performed by a qualified instrument technician. If service facilities are not available, return the instrument to the factory. Refer to the accompanying drawings to become familiar with part names and locations. Maximum torque on all set screws is 80 oz-in.

### POTENTIOMETER REPLACEMENT

The potentiometer has a life expectancy of fifty million revolutions. As it becomes worn, the element may produce noisy signals or become non-linear. When the signal noise or non-linearity become unacceptable, replace the potentiometer as follows:

1. REMOVE POTENTIOMETER
  - a) Remove three screws which secure upper and lower sections of main housing.
  - b) Carefully remove upper housing exposing wiring connections to circuit board.
  - c) Unsolder potentiometer wires from circuit board. Note color coding.
  - d) Using a knife blade or similar instrument, loosen potentiometer assembly from upper housing and slide it out.
2. INSTALL NEW POTENTIOMETER
  - a) Slide new potentiometer cell into upper housing. Be sure to engage cell key into housing notch.
  - b) Solder potentiometer wires to circuit board. Observe color code.
  - c) Join two sections of main housing. Secure with screws removed in step 1a.
3. ALIGN VANE
  - a) Connect excitation voltage and signal conditioning electronics to instrument according to wiring diagram.
  - b) Loosen set screw in side of vane hub.
  - c) Position instrument so cross arm is oriented north-south with vane on north side. Orient vane to a known angular reference. (See CALIBRATION section.)
  - d) While holding vane in reference position, slowly turn vane skirt until signal conditioning system indicates proper value.
  - e) Tighten set screw on side of vane hub. Do not exceed 80 oz-in torque.

## **ANEMOMETER FLANGE BEARING REPLACEMENT**

If anemometer bearings become noisy or wind speed threshold increases above an acceptable level, replace the bearings. Check bearing condition by hanging an ordinary paper clip (0.5 gm) on the outside edge of one cup while the instrument is held in a horizontal position. The cup should rotate downward. Failure to rotate due to the weight of the paper clip indicates anemometer bearings need replacement. Repeat this test at different positions to check full bearing rotation. Replace bearings as follows:

1. REMOVE BEARINGS
  - a) Loosen set screw on side of cup wheel hub. Remove cup wheel.
  - b) Remove three screws which hold two sections of main housing.
  - c) Carefully separate upper and lower housing. Remove coil transducer assembly from upper housing. Do not disconnect from circuit board.
  - d) Loosen screw and remove ring magnet on end of shaft inside upper housing.
  - e) Slide shaft and skirt assembly out of both upper and lower bearings.
  - f) Using knife blade under bearing flange, carefully remove upper bearing.
  - g) Using a pencil, gently push out lower bearing from above.
2. INSTALL NEW BEARINGS
  - a) Insert new upper bearing. Use care not to apply excessive pressure.
  - b) Slide cup wheel shaft through upper bearing.
  - c) Slide lower bearing on shaft inside upper housing.
  - d) Using ring magnet assembly, push lower bearing into its seat in upper housing.
  - e) Secure ring magnet to shaft using screw removed in step 1d. Use a small amount of sealant on screw to prevent it from loosening.
  - f) Join two housing sections. Secure using three screws removed in step 1b.
  - g) Place cup wheel on shaft. Tighten set screw on side of hub. Do not exceed 80 oz-in torque.

## **VANE FLANGE BEARING REPLACEMENT**

If vane bearings become noisy or if wind direction threshold increases above an acceptable level, replace the bearings. Check bearing condition by adding two ordinary paper clips (0.5 gm each) to the back edge of the vane fin while the instrument and vane are held in a horizontal position. Gently release the vane. It should rotate downward. Failure to do so indicates the bearings need replacement. Repeat this test at various positions to check full bearing rotation. Since this procedure is similar to anemometer bearing replacement, only the major steps are shown here:

1. REMOVE BEARINGS  
(Remove coupling disc - same as ring magnet)
2. INSTALL NEW BEARINGS
3. ALIGN VANE (See CALIBRATION section)

## **EMC COMPLIANCE**

This device complies with Part 15 of the FCC Rules. Operation is subject to the following two conditions: (1) this device may not cause harmful interference, and (2) this device must accept any interference received, including interference that may cause undesired operation.

This equipment has been tested and found to comply with the limits for a Class A digital device, pursuant to part 15 of the FCC Rules. These limits are designed to provide reasonable protection against harmful interference when the equipment is operated in a commercial environment. This equipment generates, uses, and can radiate radio frequency energy and, if not installed and used in accordance with the instruction manual, may cause harmful interference to radio communications. Operation of this equipment in a residential area is likely to cause harmful interference in which case the user will be required to correct the interference at his own expense.

This ISM device complies with Canadian ICES-001.  
Cet appareil ISM est conforme à la norme NMB-001 du Canada.

EN55011/CISPR 11, Group 1, Class B device.

Class B equipment is suitable for use in domestic establishments and in establishments directly connected to a low voltage power supply network which supplies buildings used for domestic purposes.

Note:

Wind Sentry sensors with Line Driver Output may be disrupted by radiated RF interference at 240-300 MHz. To meet EMC Compliance, (2) YOUNG 18500 ferrite chokes must be installed on the cable, one near the sensor, and one near the recording instrument. (Each choke must have the cable pass through the center hole at least 2 times, creating 1 loop around the outside as shown below.)

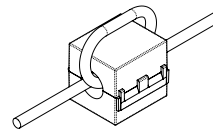

## **WARRANTY**

This product is warranted to be free of defects in materials and construction for a period of 12 months from date of initial purchase. Liability is limited to repair or replacement of defective item. A copy of the warranty policy may be obtained from R. M. Young Company.

## **CE COMPLIANCE**

This product has been tested and complies with European CE requirements for the EMC Directive. Please note that shielded cable must be used.



# CABLE & WIRING DIAGRAM

MODEL 03002L WIND SENTRY

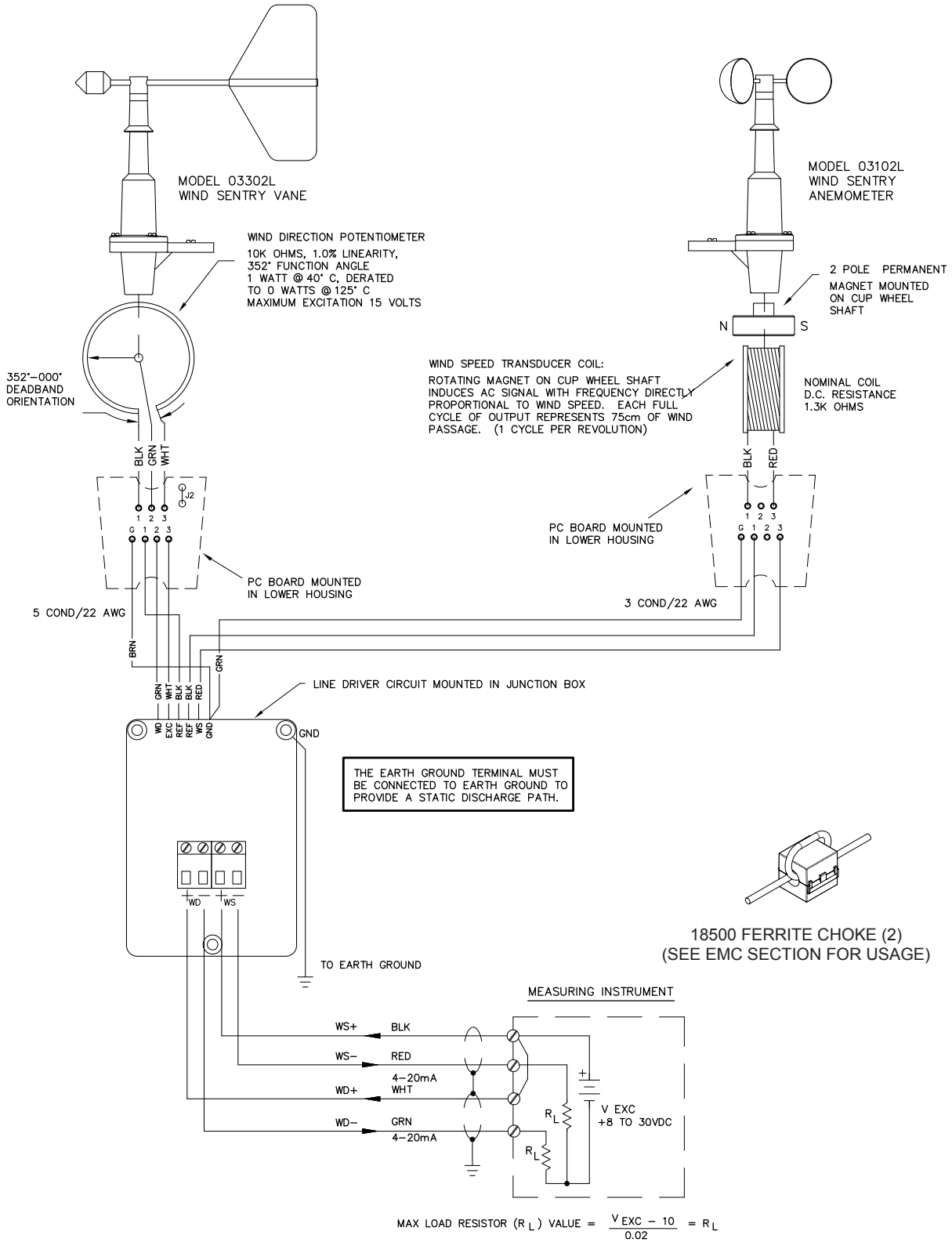



# CIRCUIT DIAGRAM

MODEL 03002I WIND SENTRY  
(03640B WIND LINE DRIVER)

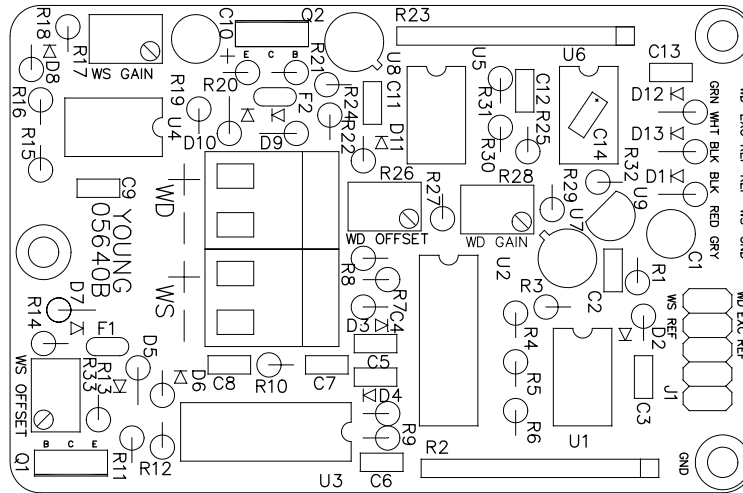

## CIRCUIT SCHEMATICS

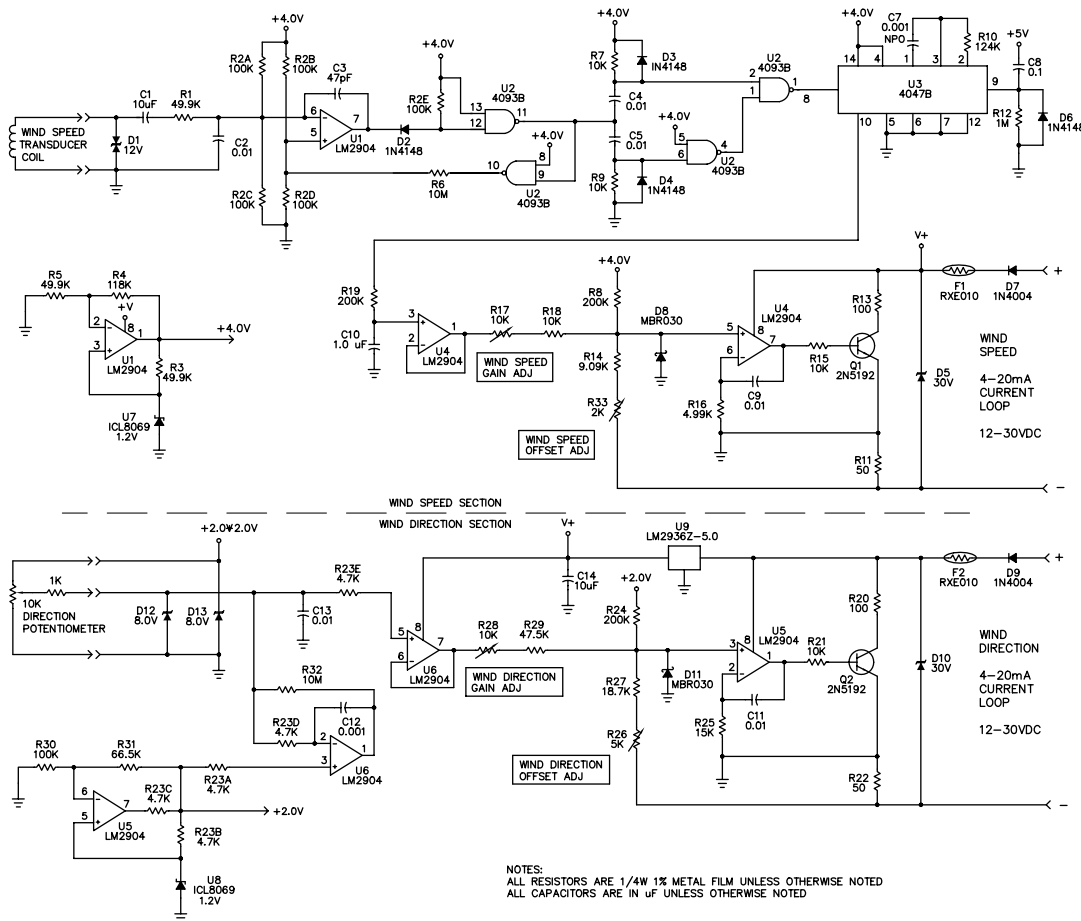



# GENERAL ASSEMBLY & REPLACEMENT PARTS

MODEL 03002L WIND SENTRY

## WIND SENTRY VANE MODEL 03302L

## WIND SENTRY ANEMOMETER MODEL 03102L

18500 FERRITE CHOKE (2)

