

## 5.0 MAINTENANCE

The MODEL 61302V barometer requires no regular maintenance. Periodic calibration certification, if required, is available from the factory.

## 6.0 WARRANTY

This product is warranted to be free of defects in materials and construction for a period of 12 months from date of initial purchase. Liability is limited to repair or replacement of defective item. A copy of the warranty policy may be obtained from R. M. Young Company.

## 7.0 CE COMPLIANCE

This product complies with European CE requirements for the EMC Directive. Please note that shielded cable must be used.

## Declaration of Conformity

R.M. Young Company  
2801 Aero Park Drive  
Traverse City, Mi 49686 USA

Model 61302V Barometric Pressure Sensor

The undersigned hereby declares on behalf of R.M. Young Company that the above-referenced product to which this declaration relates is in conformity with the provisions of:

Council Directive 2004/108/EC (December 15, 2004) on Electromagnetic Compatibility;

*David Poinsett*  
David Poinsett  
R & D Manager

## INSTRUCTIONS



**MODEL 61302V  
BAROMETRIC PRESSURE SENSOR**



## APPENDIX A

61302V BAROMETER  
TYPICAL WIRING CONNECTIONS

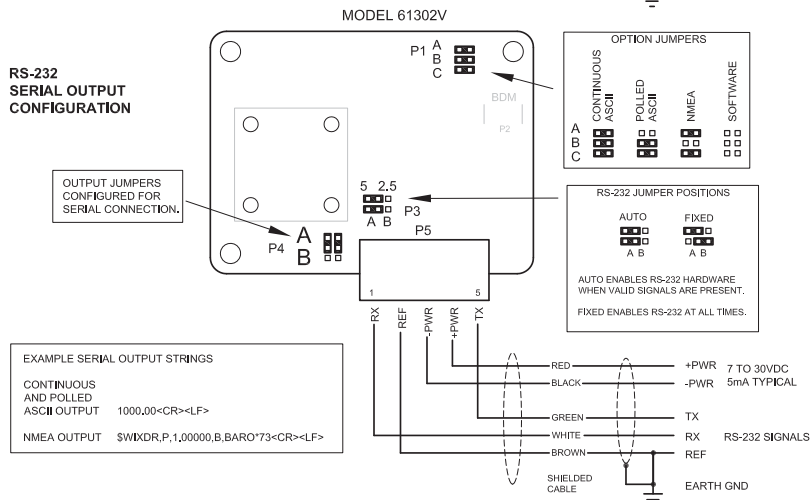
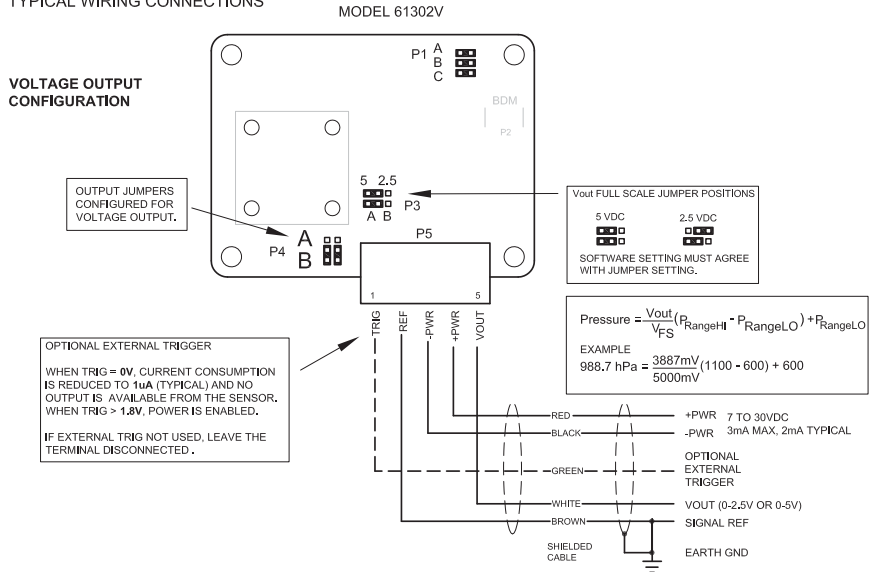

**R.M. YOUNG COMPANY**  
2801 AERO PARK DRIVE, TRAVERSE CITY, MICHIGAN 49686, USA  
TEL: (231) 946-3980 FAX: (231) 946-4772

PN: 61302V-90  
REV: H062612

## 1.0 SPECIFICATIONS

Pressure	500 to 1100 hPa standard range
Digital Accuracy*	0.2 hPa (25°C) 0.3 hPa (-40°C to +60°C)
Analog Accuracy**	0.05% of analog pressure range
Analog Temperature Dependence**	0.0017% of analog pressure range per °C (25°C reference)
Long Term Stability:	0.2% FS per year

\*Defined as ±1 standard deviation from NIST-traceable pressure reference in clean, dry air. Includes non-linearity, hysteresis, repeatability, and calibration uncertainty.

\*\*Defined as ±1 standard deviation from ideal analog output. Total analog output accuracy is the root sum square of digital accuracy, analog accuracy, and analog temperature dependence.

Output Rate	1.8 Hz (max) to 1 per minute
Voltage Output	0 to 5000 mV (standard) 0 to 2500 mV 12-bit resolution (1 in 4000) Selectable pressure range: 500 to 1100 hPa (standard)
Serial Output	Full duplex RS-232 1200 to 38400 baud Continuous ASCII text Polled ASCII text NMEA 0.01 hPa resolution
Supply Voltage	7 to 30 VDC 2.8 mA with Vout (standard) 1.4 uA shutdown (Trig=0V) 7 mA with serial I/O
Case	Fiber-reinforced thermoplastic
Weight	44 g (1.5 oz)

## 2.0 INTRODUCTION

MODEL 61302V Barometric Pressure Sensor is a versatile electronic barometer featuring high accuracy, low power, wide operating temperature range, and calibrated voltage output or RS-232 serial data I/O.

Low power consumption and wide temperature range make the 61302V ideal for remote applications using battery or solar power.

Full scale voltage output may be set to span any portion of the 500 to 1100 hPa operating range. RS-232 serial I/O options include continuous or polled ASCII text output or NMEA marine output. The sensor is supplied with the following standard configuration:

Voltage output 0 to 5000 mV = 500 to 1100 hPa 10 samples averaged 1.8 Hz update rate
---

## 3.0 INSTALLATION

The sensor operates over a temperature range of -40°C to +60°C and must remain dry. Electrical connections are made with the 5-position terminal plug included with the sensor. Jumper settings may be used to select operating options. Access jumpers by loosening two screws in the sensor enclosure and removing the cover. See Appendix A for wiring details and jumper settings.

If changed from the standard configuration, please note that the software Vout Scale parameter must be set to agree with the hardware Voltage Output Scale jumper (P3) in order to achieve calibrated output.

## 4.0 OPERATION

Operation begins approximately 1 second after power is applied. Output will appear after a delay determined by the number of samples averaged and the output rate. With default values (1.8 Hz output and 10 samples averaged), outputs will begin after an initial 5 second delay then remain continuous at the 1.8 Hz rate. Parameters for output rate and number of samples averaged may be changed using software commands.

### 4.1 VOLTAGE OUTPUT

Hardware jumpers and software parameters determine voltage output operation. Appendix A shows jumper configurations.

Both P4 jumpers must be in position B for voltage output.

Jumper P3 sets the Voltage Output Scale to either 0-5000 mV or 0-2500 mV. Please note that jumper P3 **must** agree with the software Vout Scale parameter in order to achieve calibrated output.

The voltage output scale may be mapped to any part of the 500 to 1100 hPa pressure range using the VOUT HI and VOUT LO software parameters. The standard setting maps 0 to 5000 mV with 500 to 1100 hPa. With this setting:

$$\text{hPa} = 0.12 * \text{mV} + 500$$

Effective resolution is about 0.15 hPa

Better effective resolution may be achieved by mapping the voltage output to a narrower range of pressure with the VOUT HI and VOUT LO parameters. For example, with VOUT LO set to 950 hPa and VOUT HI set to 1050 hPa and the VOUT Scale set to 0-5000 mV:

$$\text{hPa} = 0.02 * \text{mV} + 950$$

Effective resolution is about 0.025 hPa

Please see section 4.3 below for details on changing the VOUT HI and LO parameters.

With jumper P4 configured for voltage output, a special TRIG input may be used to control barometer power. When TRIG=0V, all processes cease and power consumption is reduced to 1.4uA. When the voltage on TRIG > 1.8V (or left floating), normal operation resumes with a powerup reset. The TRIG input connection is optional. It may be connected to +PWR or left floating.

### 4.2 SERIAL OUTPUT

Jumper settings and software parameters determine RS-232 serial communication format. The Appendix A Wiring Diagram shows jumper locations and function.

P1 A/B/C sets output format, baud rate, output rate, and averaging. The table below summarizes P1 configurations.

P3 A/B sets RS-232 hardware function. AUTO (A) enables RS-232 hardware when valid standard RS-232 signals are present at RX and TX. When not present, the RS-232 hardware is disabled to save power. FIXED (B) enables RS-232 hardware at all times so it can be used with some non-standard RS-232 signals.

P4 A/B configures the terminal connections for RS-232. Both jumpers must be in position A for RS-232 serial communication.

Format	Description
Continuous ASCII Text (standard)	9600 baud 10 sample average 1.8 Hz output
Polled ASCII Text	9600 baud 10 sample average Output when polled
Marine NMEA	4800 baud 10 sample average 1Hz output
Software	Output parameters determined by software settings

Note that NMEA output is normally specified to work on RS-422 and RS-485 networks. The NMEA output here conforms to the standard data format but the electrical connection uses RS-232 signal levels.

In POLLED ASCII mode, the unit sends data only after receiving a poll command. The poll command is Ma! where 'a' is the address value. The standard address is '0' (ASCII 48) for a poll command of M0! Please see section 4.3 for details on changing the poll address.

Standard baud rate is 9600 but any of several available baud rates between 1200 and 38400 may be used.

### 4.3 SOFTWARE COMMANDS

Software commands sent via serial communication may be used to set operational parameters. The sensor must be configured for serial communication and connected to a PC or other compatible device using a program like HyperTerm.

**New settings are stored in temporary memory and must be burned to flash with command CMD420 to be retained.**

Note that the P1 jumper must be configured for SOFTWARE format to alter baud rate, sample average count, and output rate parameters.

Although the sensor may receive commands at any time, measurement output may be paused by sending three ESC (ASCII 27) characters or CMD300 1. While paused, COMMAND mode is indicated by a ">" prompt. All commands must be terminated with a carriage return CR (ASCII 13).

Use "?" to list available commands as shown below.

>?

```

YOUNG 61300 SERIES BAROMETER V2.03
-----
CMD100 n  OUTPUT PERIOD (0-60 sec)
CMD105 n  AVG SAMPLE COUNT (0-32)
CMD110 n  OUTPUT FORMAT
          (1=ASCII 2=POLLED 3=NMEA 4=RAW 5=DIAG)
  
```

```

CMD120 n  MULTIPLIER (10000 = 1.0000)
CMD125 n  OFFSET (hPa x 100)
CMD130 n  SEA LEVEL CORRECTION (hPa x 100)
CMD140 n  VOUT RANGE HI (500-1100)
CMD142 n  VOUT RANGE LO (500-1100)
CMD144 n  VOUT SCALE (2=2.5V 5=5V)
CMD150 c  POLL ADDR CHAR
CMD160 n  BAUD RATE (38400,9600,4800,2400,1200)
CMD165 n  1=STOP, 2=RUN
CMD170 n  FORCE VOUT (0-5000 FULL SCALE)
CMD400 n  1=RPT TEXT, 2=RPT CODE ONLY
CMD410    GET CAL TABLE
CMD420    STORE SETUP PARAMETERS
  
```

>  
**CMD100 n** sets output period in seconds. When set to zero, the output rate is about 1.8 per second.

**CMD105 n** sets the average sample count. Higher sample count yields more stable readings but will lengthen the startup delay.

**CMD110 n** sets output format. RAW and DIAG settings are for factory use only.

**CMD120 n** sets the output multiplier. 10000 represents 1.0000

**CMD125 n** sets the output offset in hPa x 100

**CMD130 n** sets the sea level correction in hPa x 100

$$= [P_{\text{unadjust}} * (\text{Mult} / 10000)] + [(\text{Offset} / 100) + (\text{Correction}_{\text{Sea Lvl}} / 100)]$$

**CMD140 n** sets the Vout Pressure Range HI

**CMD142 n** sets the Vout Pressure Range LO  
 Vout Pressure Range HI must be greater than Vout Pressure Range LO

**CMD144 n** sets the Vout Scale. 2 = 0 to 2500 mV. 5 = 0 to 5000 mV. This parameter setting must agree with the physical P3 jumper position to achieve calibrated voltage output.

**CMD150 c** sets the poll address character. Any ASCII character from '0' (ASCII 48) to 'z' (ASCII 122) may be used.

**CMD160 n** sets the baud rate. Acceptable values are 38400, 9600, 4800, 2400, and 1200. Note that the baud rate change occurs immediately after the command is received. Therefore, in order to continue communicating, the serial communication program that issued the command must also change to match.

**CMD300 n** causes the sensor to pause or resume measurement. 1 = Stop, 2 = Run.

**CMD400 n** causes the sensor to issue a report summarizing parameter settings.  
 1 = RPT text  
 2 = RPT code only

**CMD410** retrieves the internal calibration table. This is for factory use only.

**CMD420** burns new parameter settings to flash memory. This step **must** take place to retain changes otherwise parameters will revert to the previous values at the next powerup.